

SECTION A-A

DO NOT SCALE DRAWING

REV 1

Pilot-PA-13mm-2.5mm-S-P-BT-Machining

This product may be covered by one or more patents or
 patent applications.
 See <http://www.standardlifters.com/patents.html> for details.

STANDARD LIFTERS INC

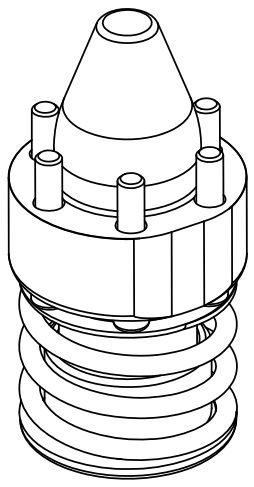
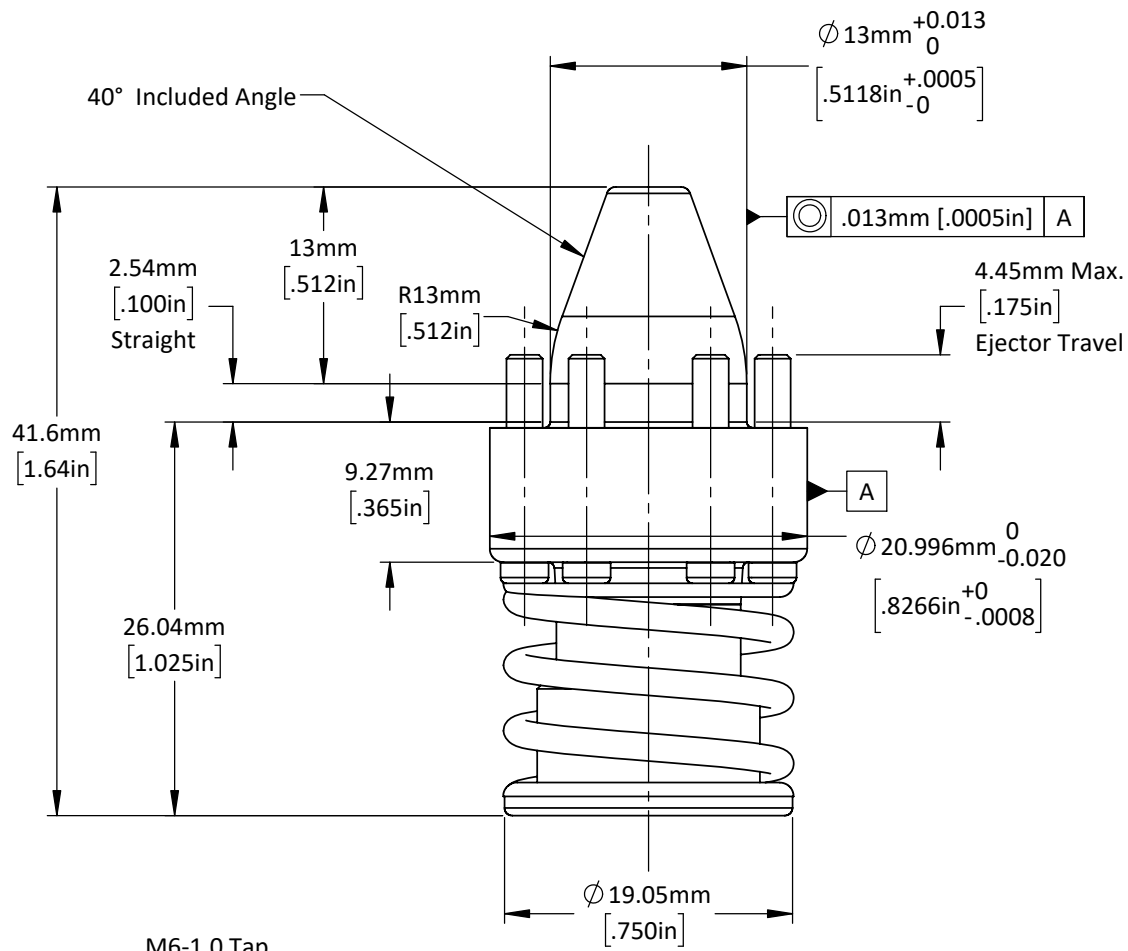
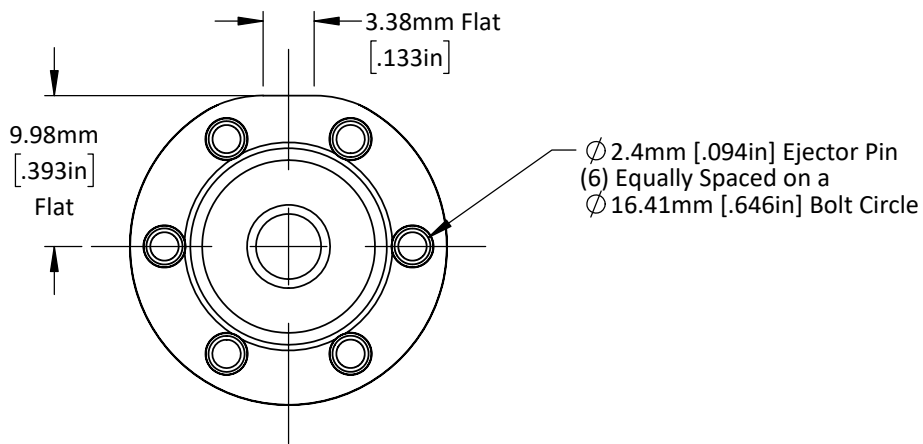

M6-1.0 Tap
11.9mm [.47in] Dp. Full Thd.

