

DO NOT SCALE DRAWING

REV 1

Pilot-PA-10mm-1.9mm-L-P-BT-Machining

This product may be covered by one or more patents or patent applications.
 See <http://www.standardlifters.com/patents.html> for details.

STANDARD LIFTERS INC

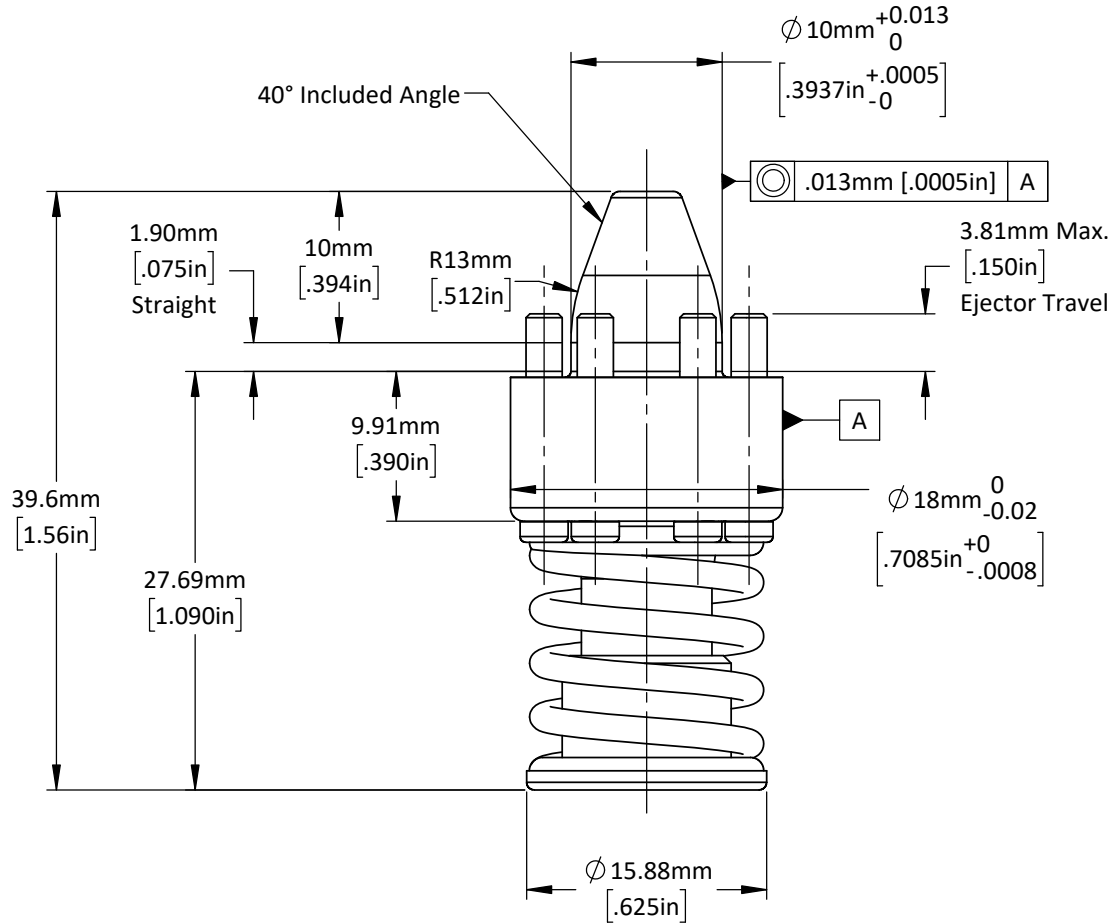
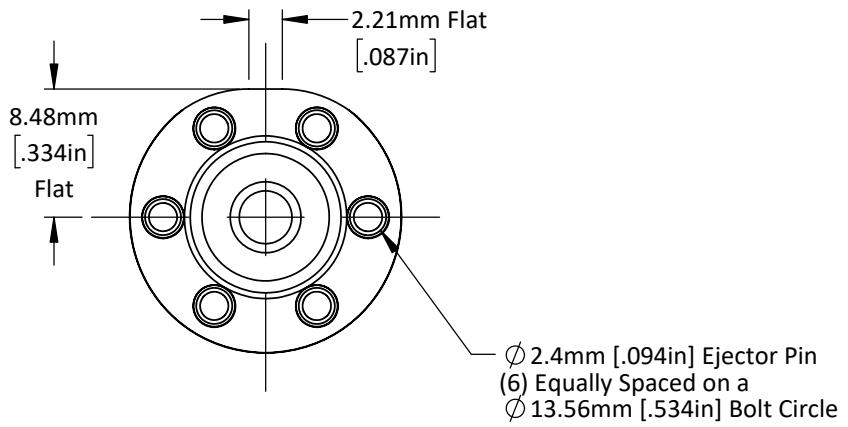

M5-0.8 Tap
10.2mm [.40in] Dp. Full Thd.

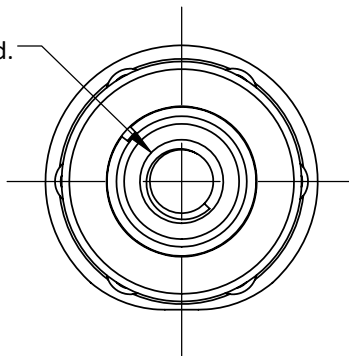
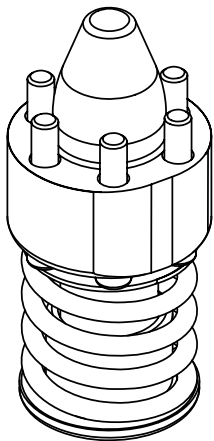

DO NOT SCALE DRAWING

REV 1

This product may be covered by one or more patents or patent applications.
See <http://www.standardlifters.com/patents.html> for details.

Pilot-PA-10mm-1.9mm-L-P-BT

STANDARD LIFTERS INC