

DO NOT SCALE DRAWING

REV 1

This product may be covered by one or more patents or
 patent applications.
 See <http://www.standardlifters.com/patents.html> for details.

Pilot-PA-.500-.100-L-P-BT-Machining

STANDARD LIFTERS INC

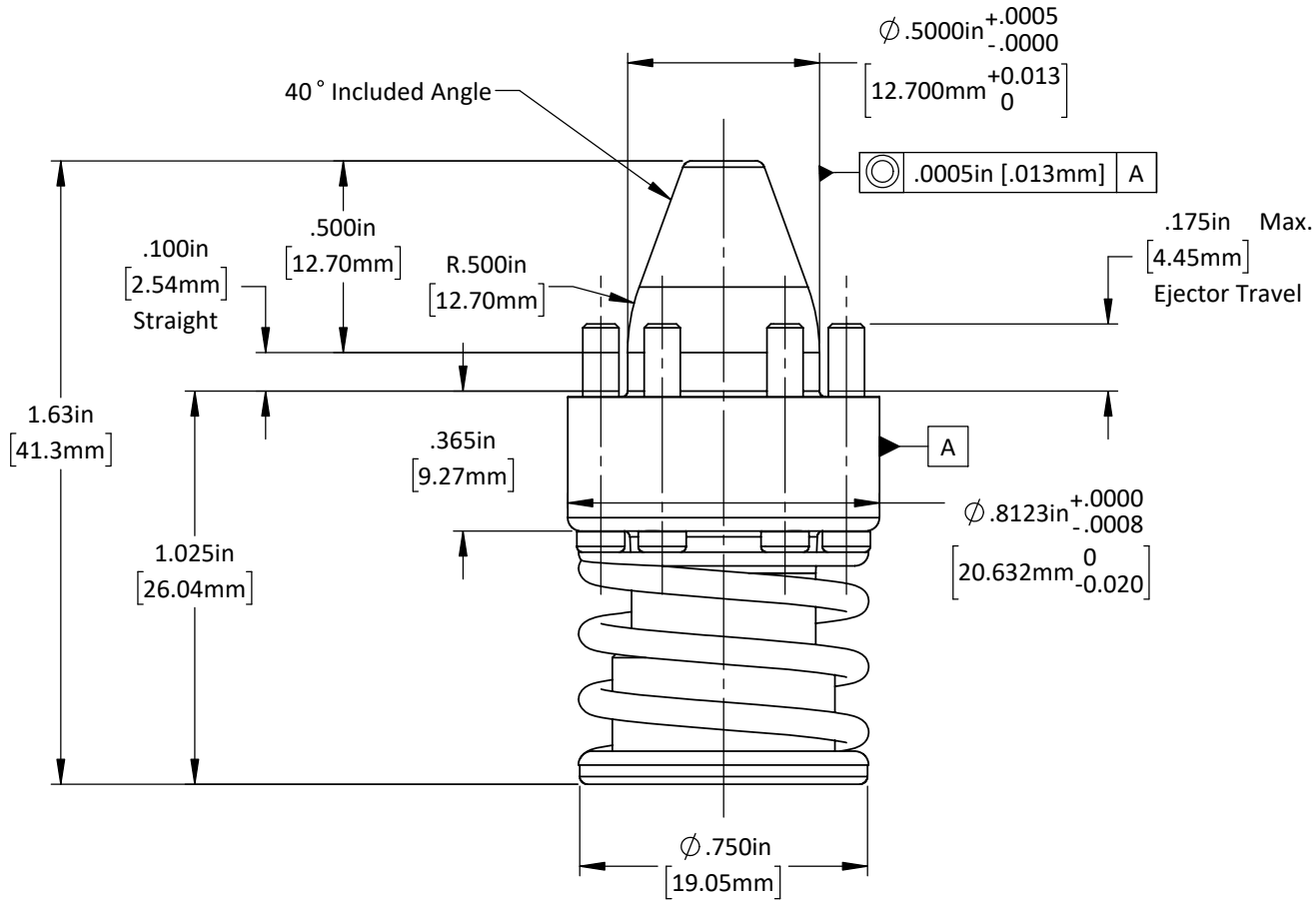
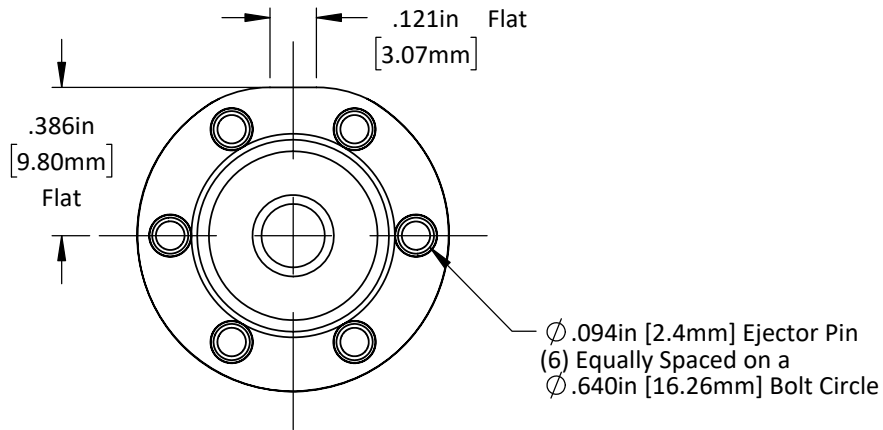

1/4-20 Tap
.50 Dp. Full Thd.

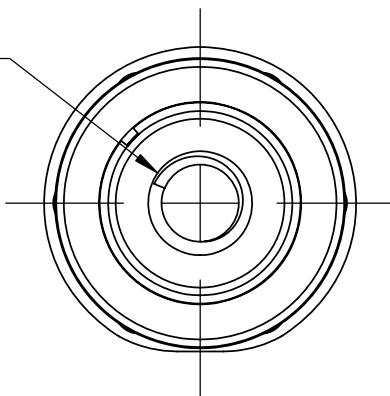
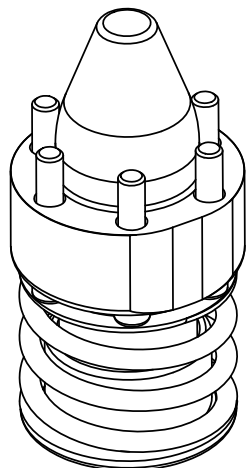

DO NOT SCALE DRAWING

REV 1

This product may be covered by one or more patents or patent applications.
See <http://www.standardlifters.com/patents.html> for details.

Pilot-PA-.500-.100-L-P-BT

STANDARD LIFTERS INC