

Ø 15.478mm Drill X Depth Shown
[.6094in]

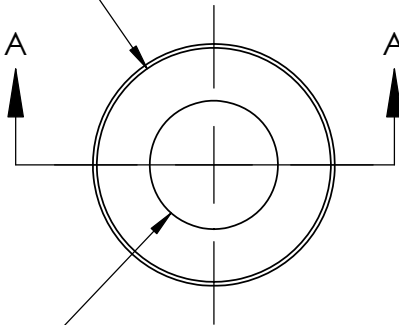

Clearance for M8 SHCS

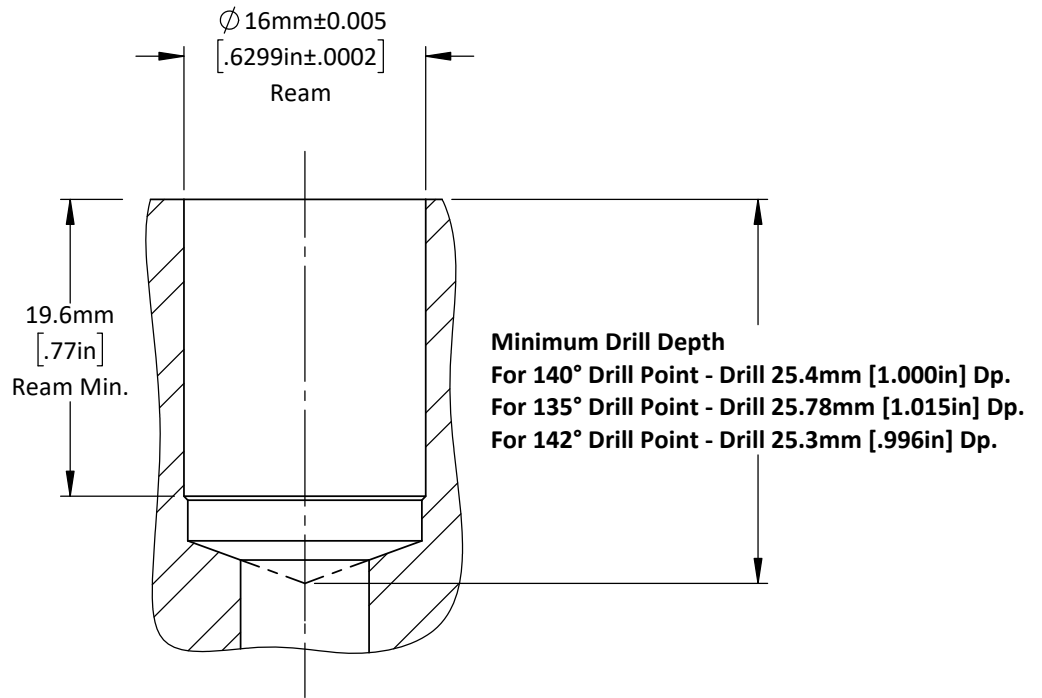

SECTION A-A

***Not to be used in Hardened Details**

DO NOT SCALE DRAWING

REV 1

This product may be covered by one or more patents or patent applications.
See <http://www.standardlifters.com/patents.html> for details.

Pilot-P-16mm-3.2mm-BT-Machining

STANDARD LIFTERS INC

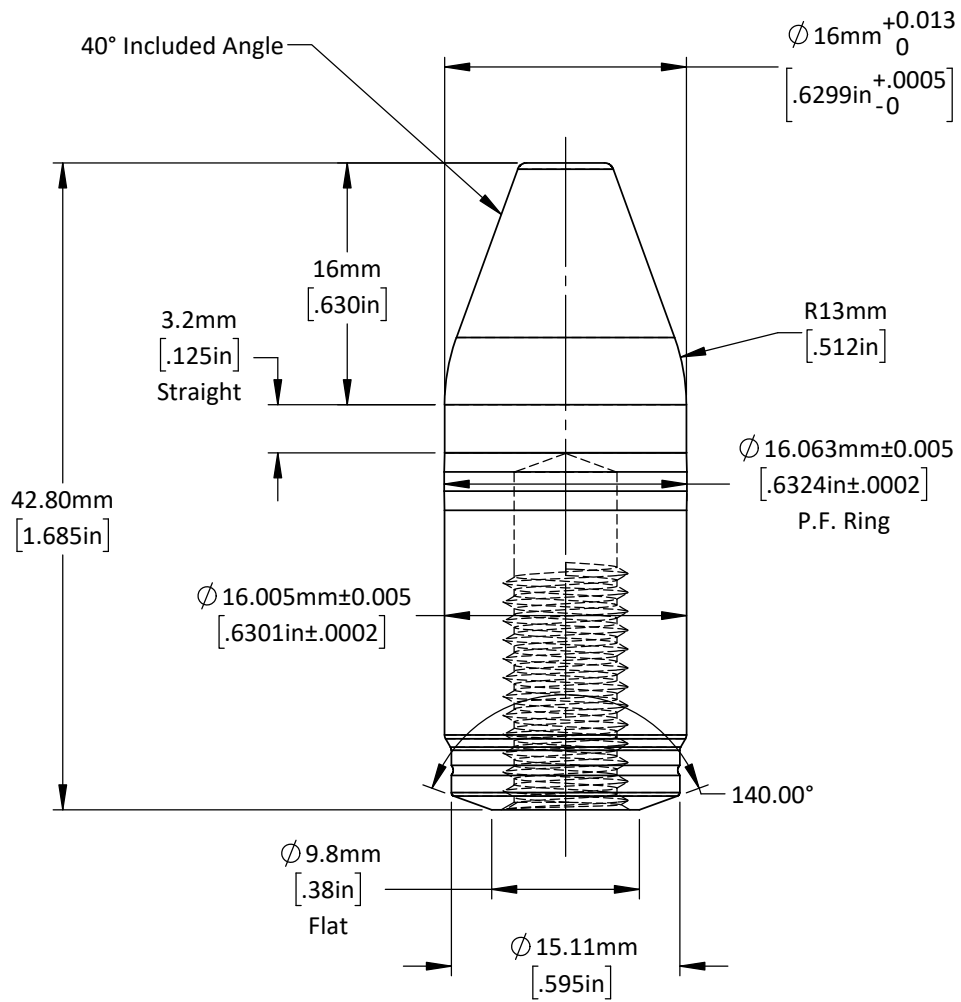

M8-1.25 Tap
 14.5mm [.57in] Dp. Full Thd.

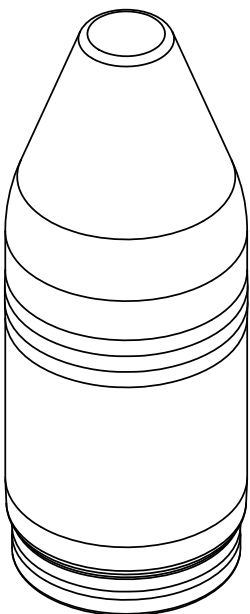
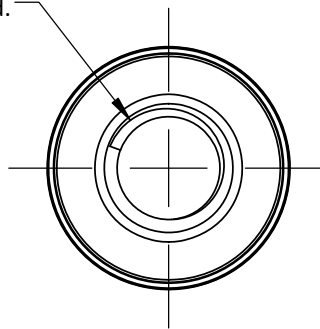

***Not to be used in Hardened Details**

DO NOT SCALE DRAWING

REV 1

This product may be covered by one or more patents or patent applications.
 See <http://www.standardlifters.com/patents.html> for details.

Pilot-P-16mm-3.2mm-BT

STANDARD LIFTERS INC