

Ø 12.70mm Drill X Depth Shown
[.500in]

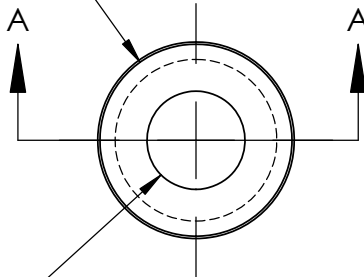

Clearance for M6 SHCS

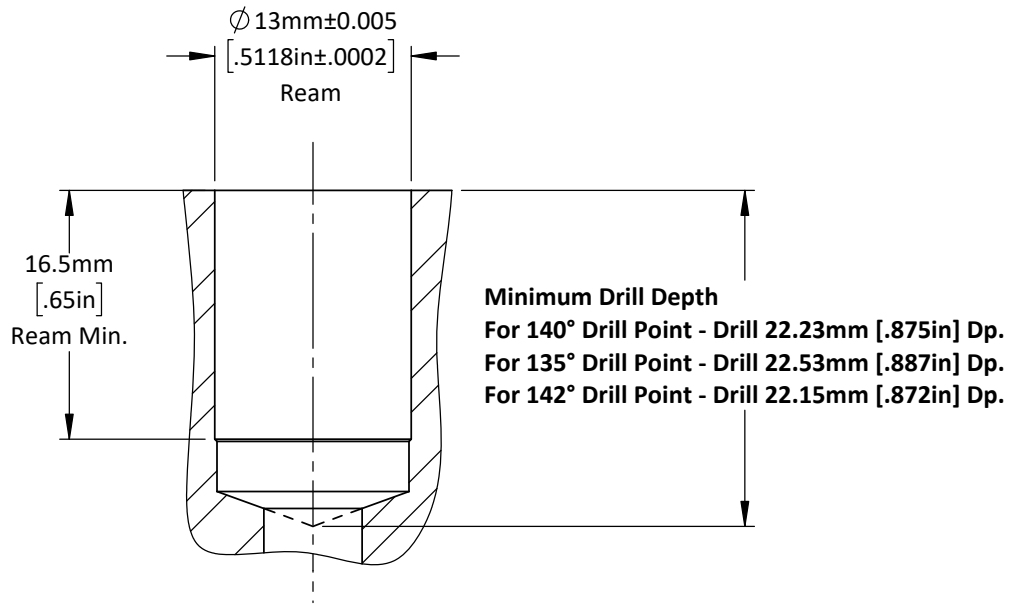

SECTION A-A

***Not to be used in Hardened Details**

DO NOT SCALE DRAWING

REV 1

This product may be covered by one or more patents or patent applications.
See <http://www.standardlifters.com/patents.html> for details.

Pilot-P-13mm-2.5mm-BT-Machining

STANDARD LIFTERS INC

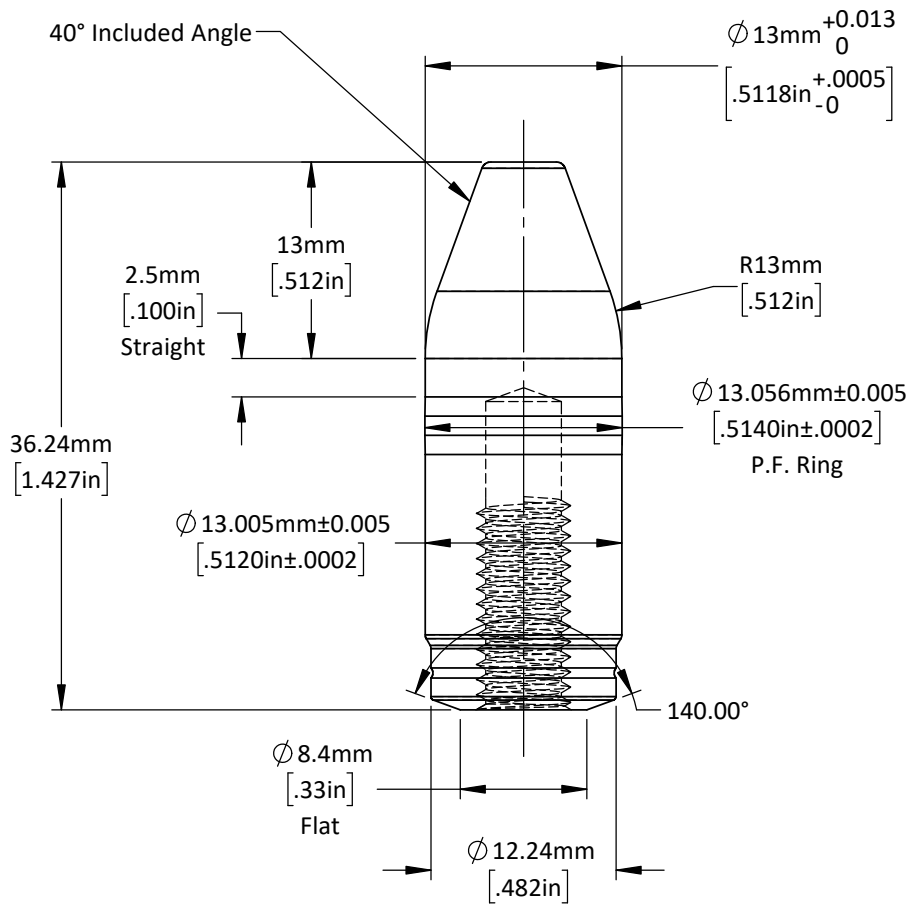

M6-1.0 Tap
12mm [.47in] Dp. Full Thd.

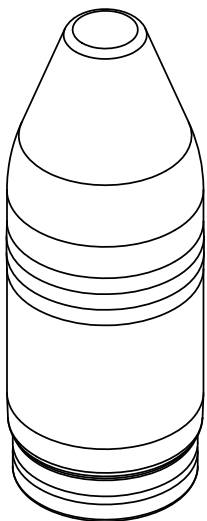
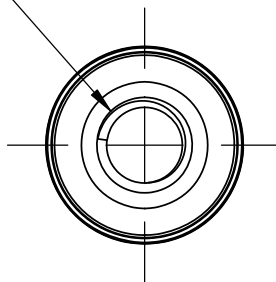

***Not to be used in Hardened Details**

DO NOT SCALE DRAWING

REV 1

This product may be covered by one or more patents or patent applications.
See <http://www.standardlifters.com/patents.html> for details.

Pilot-P-13mm-2.5mm-BT

STANDARD LIFTERS INC