

SECTION A-A

**\*Not to be used in Hardened Details**

DO NOT SCALE DRAWING

REV 1

This product may be covered by one or more patents or patent applications.  
See <http://www.standardlifters.com/patents.html> for details.

**Pilot-P-10mm-1.9mm-BT-Machining**

**STANDARD LIFTERS INC**

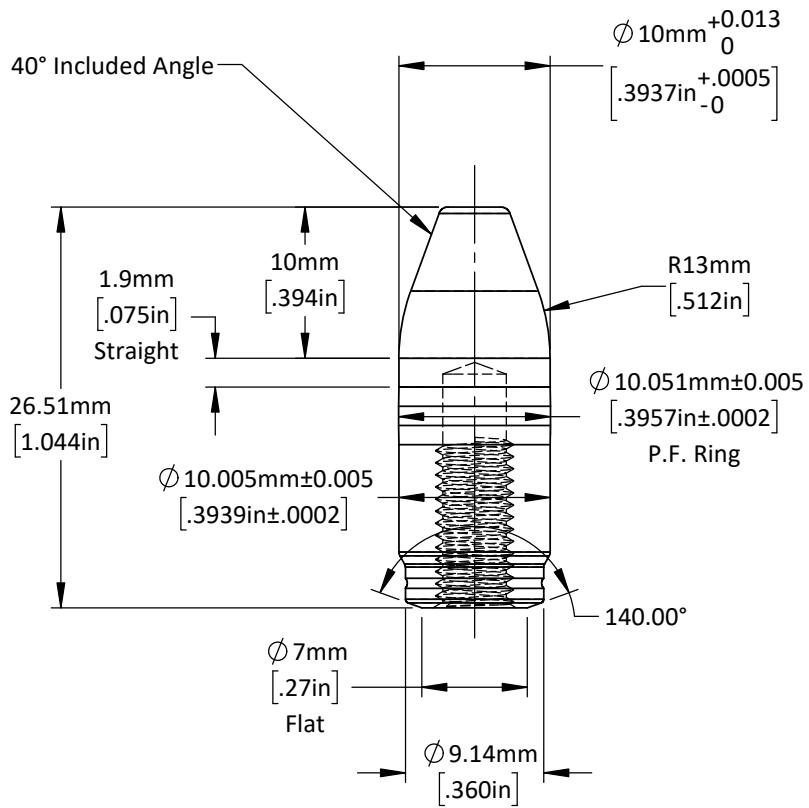

M5-0.8 Tap  
 10.1mm [.40in] Dp. Full Thd.

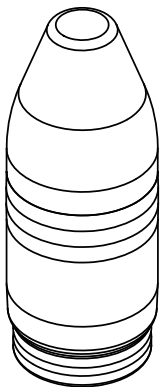
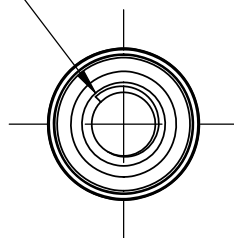

**\*Not to be used in Hardened Details**

DO NOT SCALE DRAWING

REV 1

This product may be covered by one or more patents or patent applications.  
 See <http://www.standardlifters.com/patents.html> for details.

**Pilot-P-10mm-1.9mm-BT**

**STANDARD LIFTERS INC**