

SECTION A-A

DO NOT SCALE DRAWING REV 1

This product may be covered by one or more patents or patent applications.
 See <http://www.standardlifters.com/patents.html> for details.

Pilot-P-.500-.100-F-Machining

STANDARD LIFTERS INC

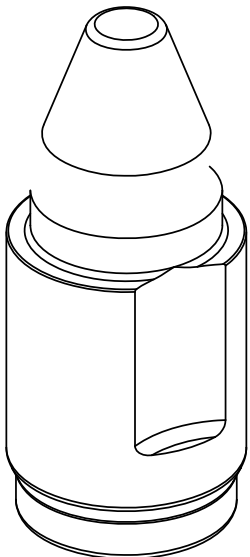
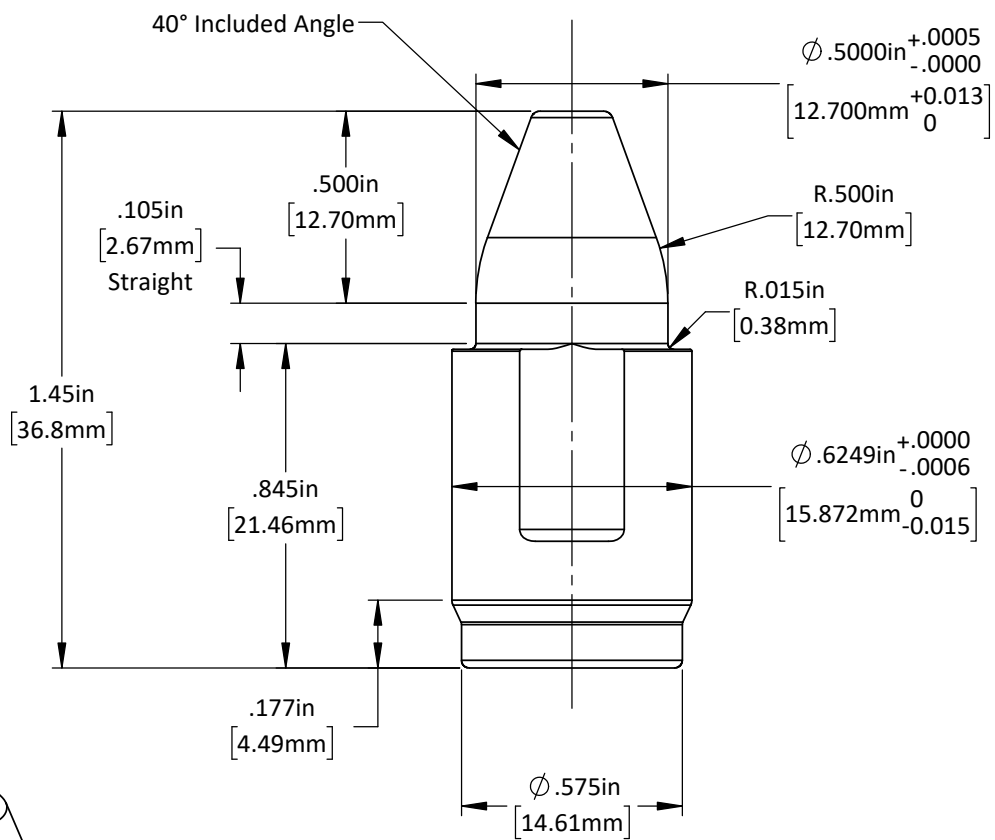
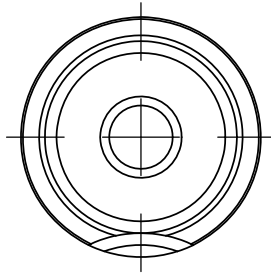

DO NOT SCALE DRAWING

REV 1

This product may be covered by one or more patents or patent applications.
See <http://www.standardlifters.com/patents.html> for details.

Pilot-P-.500-.100-F

STANDARD LIFTERS INC