

$\varnothing .4844\text{in}$  Drill X Depth Shown  
[12.303mm]

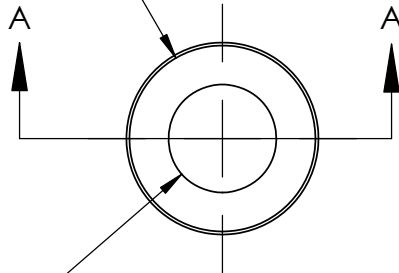

Clearance for 1/4 SHCS

$\varnothing .5000\text{in}\pm.0002$   
[12.700mm $\pm$ 0.005]

Ream

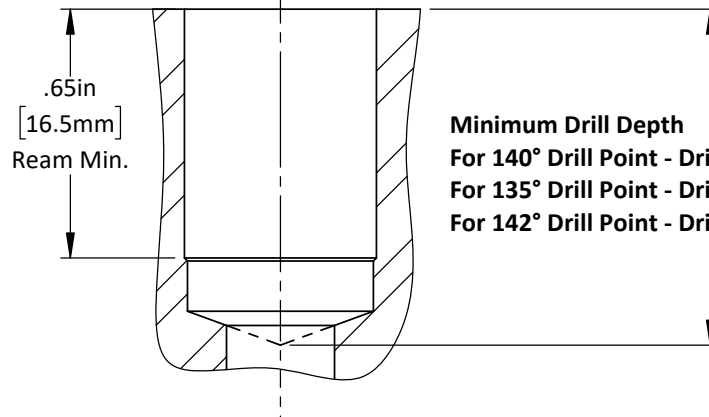

SECTION A-A

**\*Not to be used in Hardened Details**

DO NOT SCALE DRAWING

REV 1

This product may be covered by one or more patents or patent applications.  
See <http://www.standardlifters.com/patents.html> for details.

**Pilot-P-.500-.100-BT-Machining**

**STANDARD LIFTERS INC**

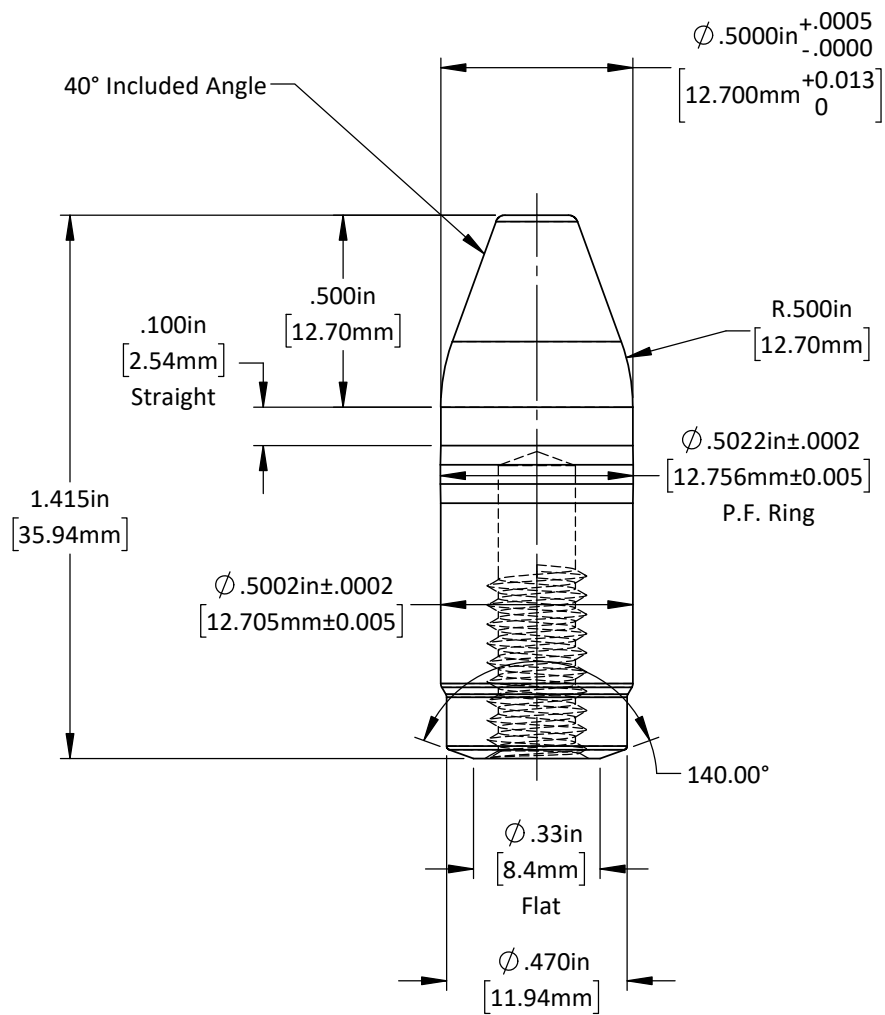

1/4-20 Tap  
 .50 Dp. Full Thd.

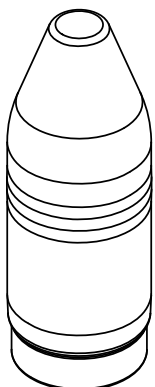
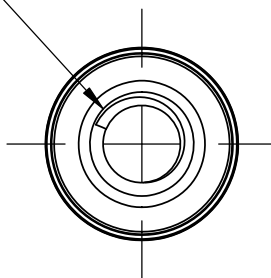

**\*Not to be used in Hardened Details**

DO NOT SCALE DRAWING

REV 1

This product may be covered by one or more patents or patent applications.  
 See <http://www.standardlifters.com/patents.html> for details.

**Pilot-P-.500-.100-BT**

**STANDARD LIFTERS INC**