

SECTION A-A

***Not to be used in Hardened Details**

DO NOT SCALE DRAWING	REV 1
This product may be covered by one or more patents or patent applications. See http://www.standardlifters.com/patents.html for details.	

Pilot-P-.375-.075-BT-Machining
STANDARD LIFTERS INC

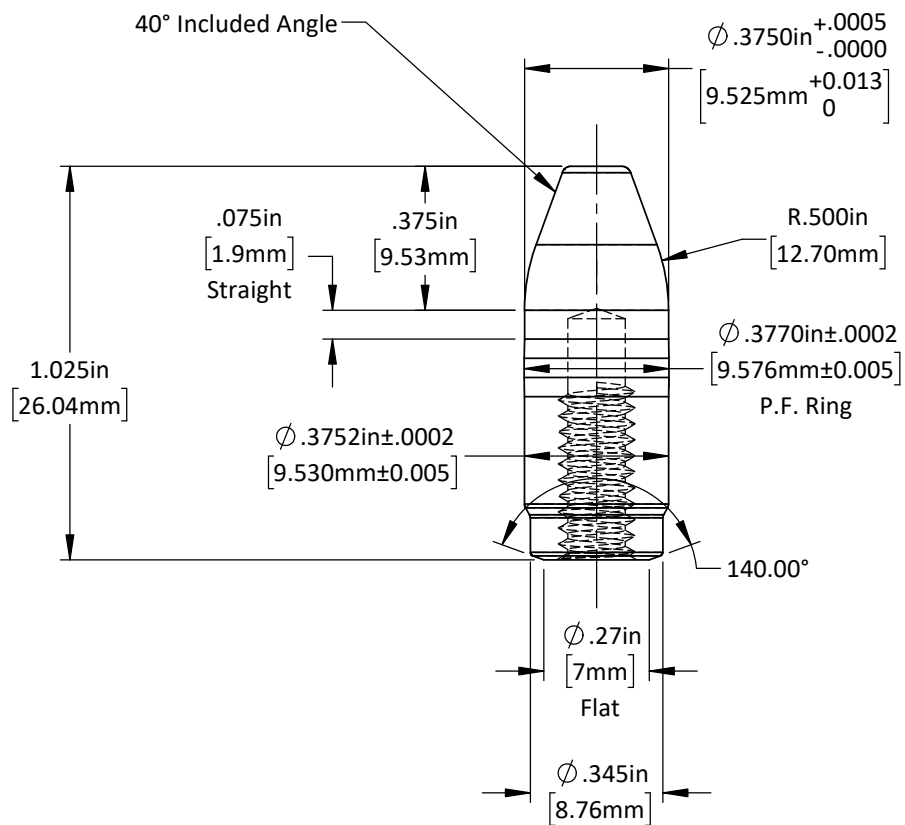

#10-24 Tap
.43 Dp. Full Thd.

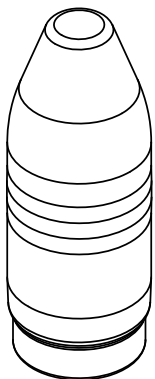
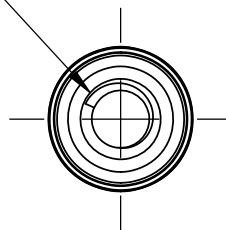

***Not to be used in Hardened Details**

DO NOT SCALE DRAWING

REV 1

This product may be covered by one or more patents or patent applications.
See <http://www.standardlifters.com/patents.html> for details.

Pilot-P-.375-.075-BT

STANDARD LIFTERS INC