

DO NOT SCALE DRAWING REV 1

This product may be covered by one or more patents or patent applications.
 See <http://www.standardlifters.com/patents.html> for details.

Guide Pin GK75-Machining

Standard Lifters Inc

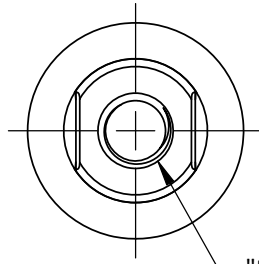

"E" = 3/8-16 Tap
0.88in Dp. Full Thd.

"M" = M10-1.5 Tap
22mm Dp. Full Thd.

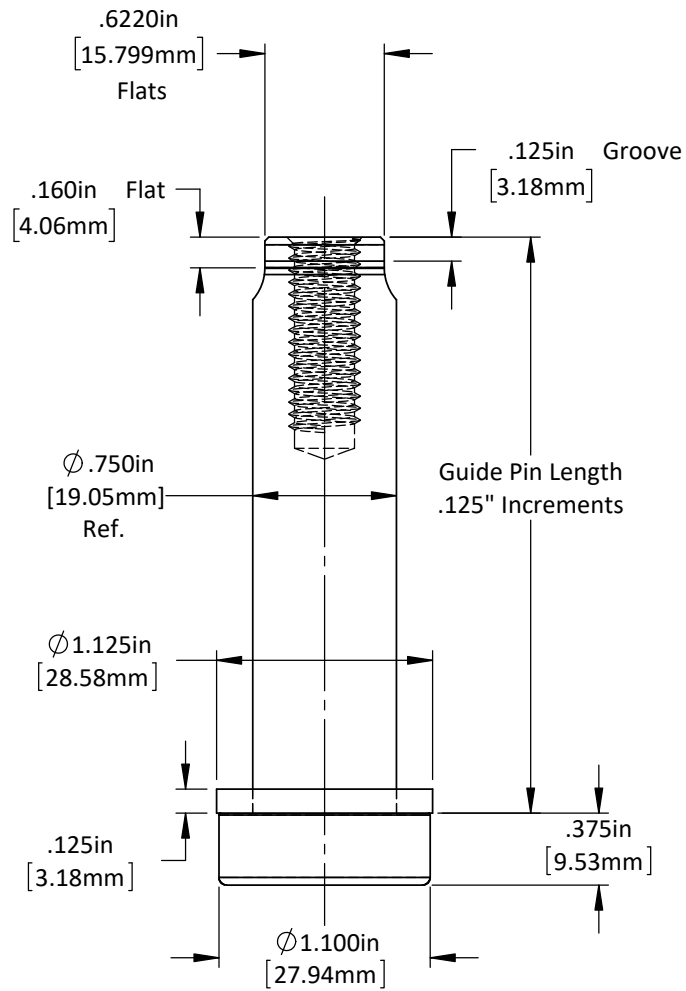
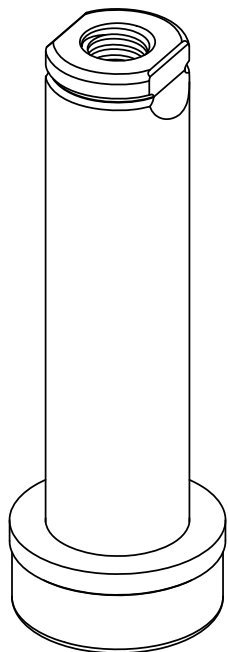

DO NOT SCALE DRAWING

REV 1

This product may be covered by one or more patents or patent applications.
See <http://www.standardlifters.com/patents.html> for details.

Guide Pin GK75

Standard Lifters Inc