

DO NOT SCALE DRAWING

REV 2

This product may be covered by one or more patents or
 patent applications.
 See <http://www.standardlifters.com/patents.html> for details.

Locking Collar GK180-Machining

Standard Lifters Inc

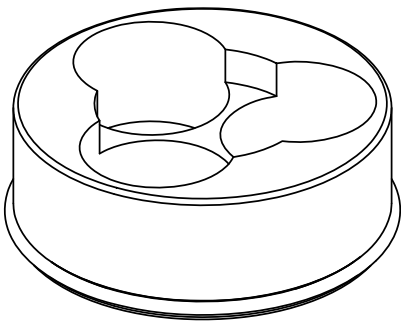
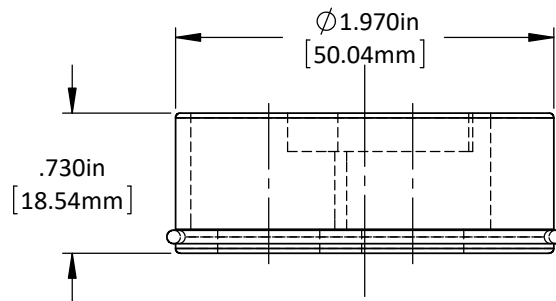
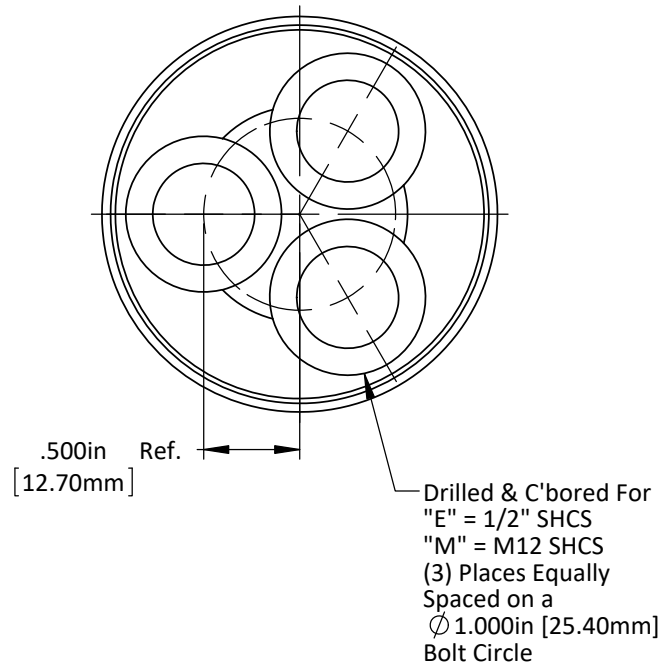

DO NOT SCALE DRAWING

REV 1

This product may be covered by one or more patents or patent applications.
See <http://www.standardlifters.com/patents.html> for details.

Locking Collar GK180

Standard Lifters Inc