

SECTION A-A

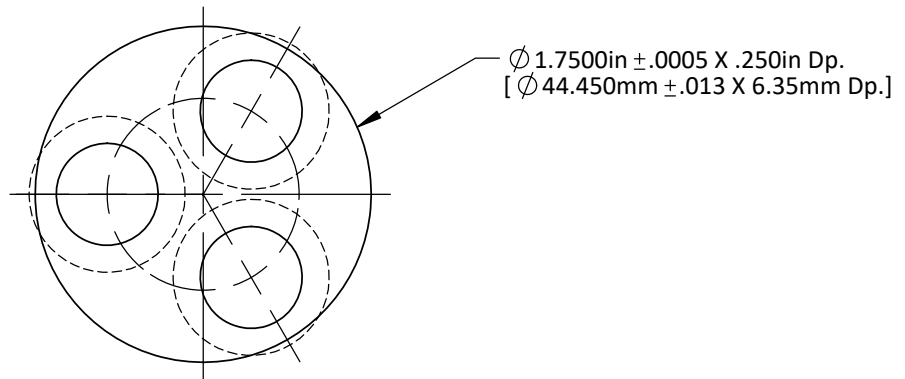

DO NOT SCALE DRAWING

REV 1

This product may be covered by one or more patents or patent applications.
 See <http://www.standardlifters.com/patents.html> for details.

Guide Pin GK180-Machining

Standard Lifters Inc

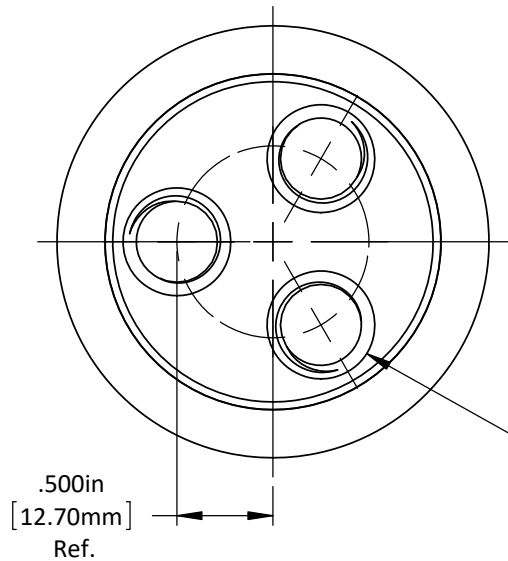

"E" = 1/2"-13 Tap
 1.12in Dp. Full Thd.
 "M" = M12-1.75 Tap
 28mm Dp. Full Thd.
 (3) Places Equally Spaced
 On a ϕ 1.000in [25.4mm]
 Bolt Circle

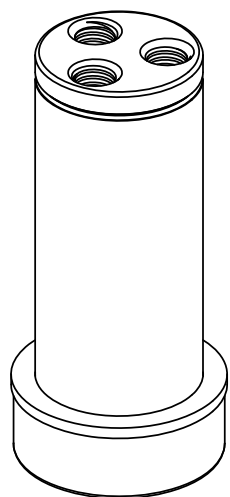
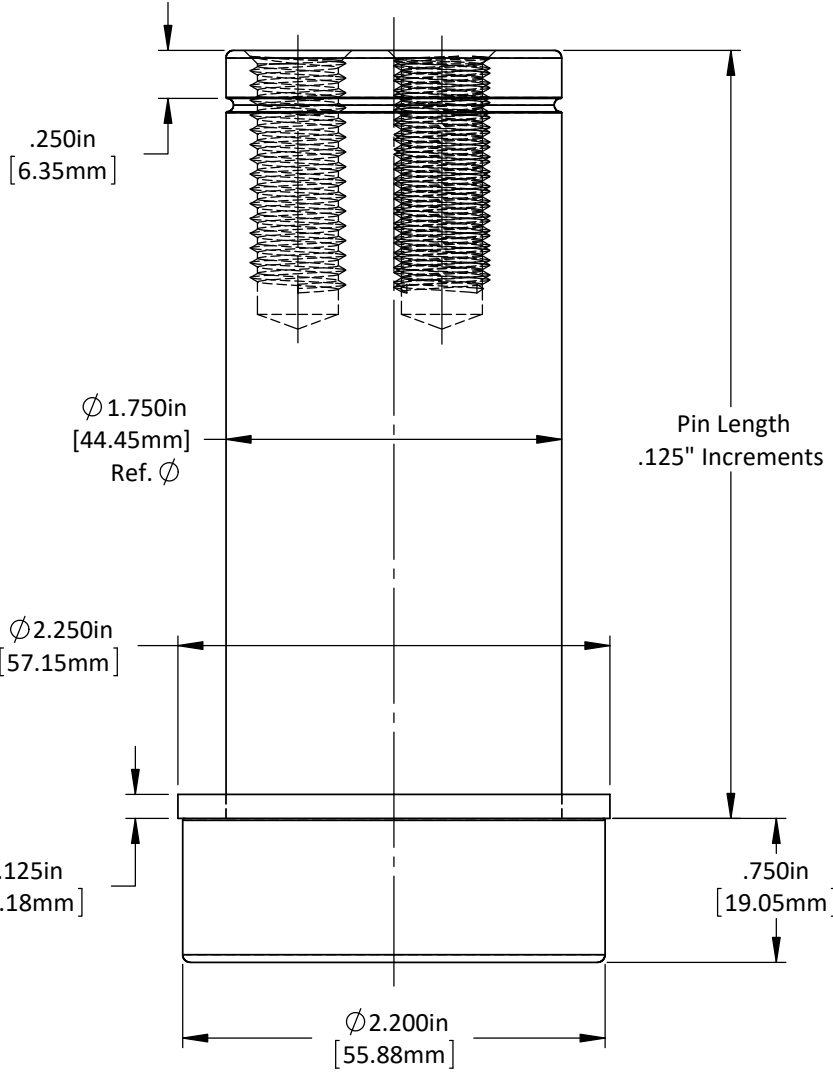

DO NOT SCALE DRAWING REV 1
 This product may be covered by one or more patents or patent applications.
 See <http://www.standardlifters.com/patents.html> for details.

Guide Pin GK180
Standard Lifters Inc