

DO NOT SCALE DRAWING REV 2

This product may be covered by one or more patents or patent applications.
 See <http://www.standardlifters.com/patents.html> for details.

Guide Pin GK122-Machining
Standard Lifters Inc

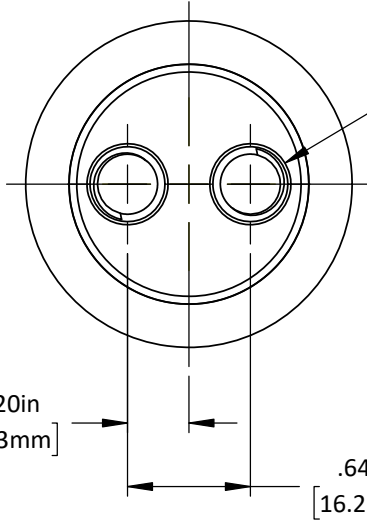

"E" = ϕ .394in Dr. X .70in Dp.
 3/8"-16 Tap X 1.50in Dp. Full Thd.
 "M" = ϕ 10.3mm Dr. X 17.8mm Dp.
 M10-1.5 Tap X 38mm Dp. Full Thd.
 (2) Plcs.

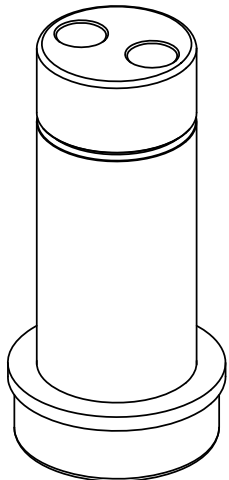
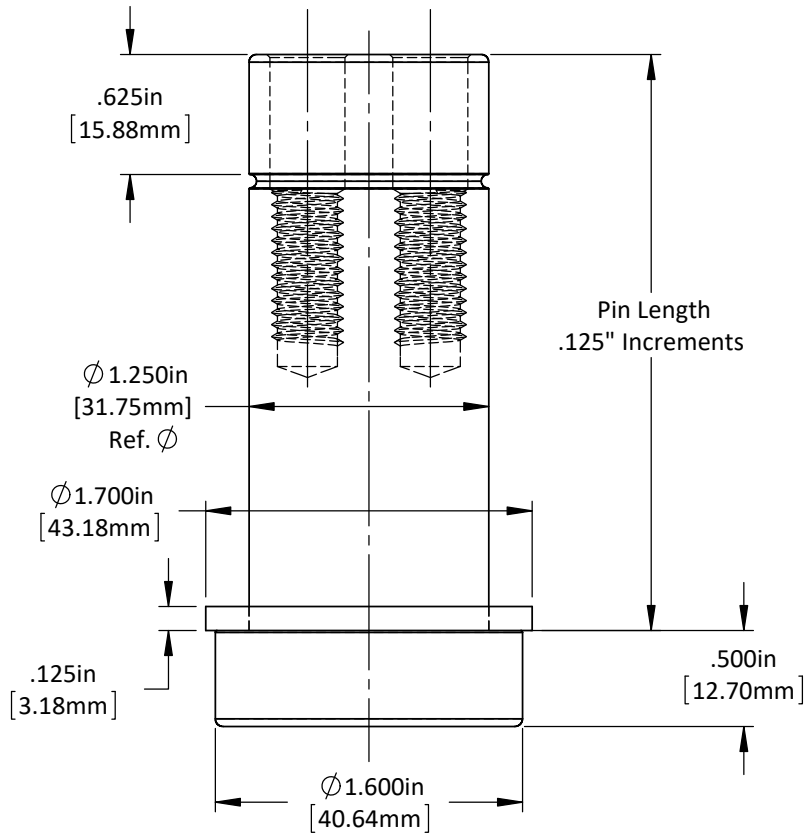

DO NOT SCALE DRAWING REV 1
 This product may be covered by one or more patents or patent applications.
 See <http://www.standardlifters.com/patents.html> for details.

Guide Pin GK122
Standard Lifters Inc