

***Caution: English & Metric Hole Locations are NOT the Same!**

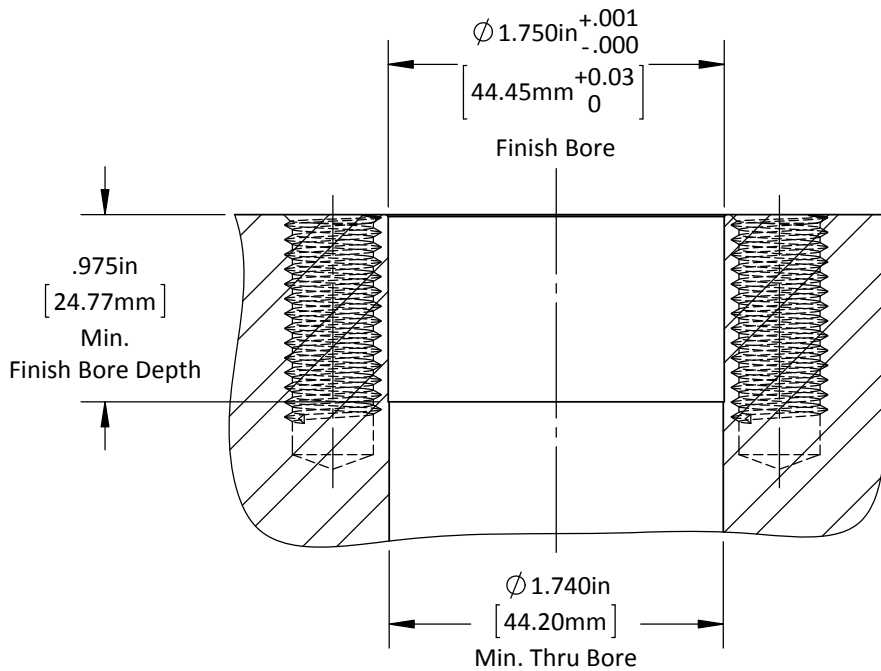
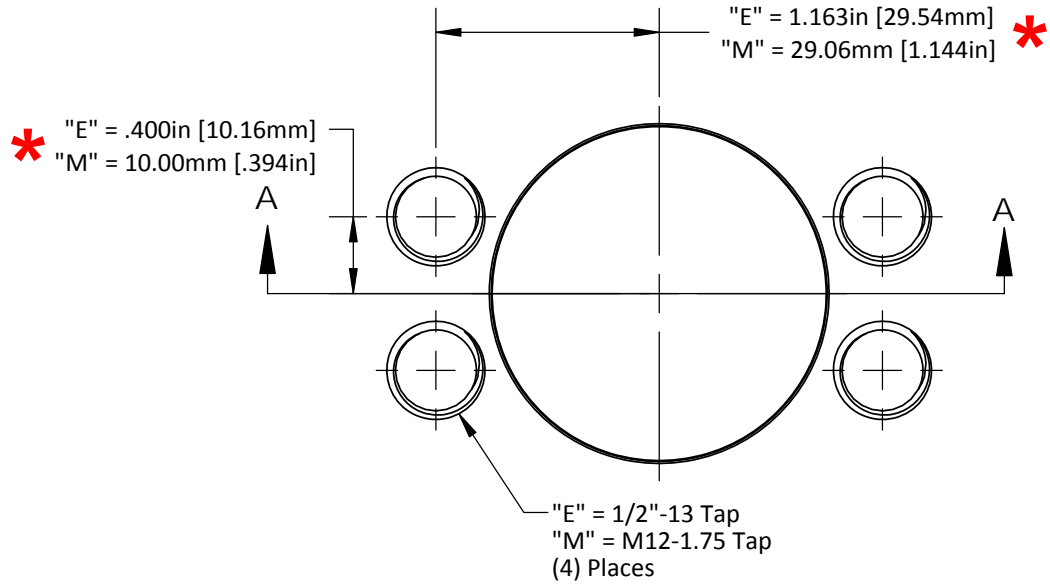

DO NOT SCALE DRAWING

REV 2

This product may be covered by one or more patents or patent applications.
See <http://www.standardlifters.com/patents.html> for details.

GK120-L2-Base Machining

STANDARD LIFTERS INC

***Caution: English & Metric Hole Locations are NOT the Same!**

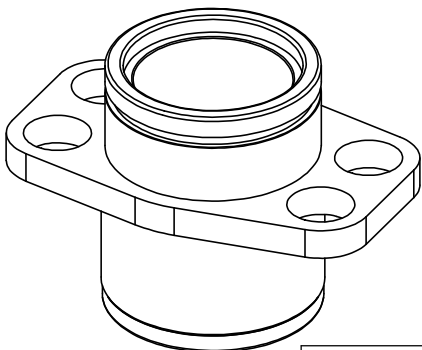
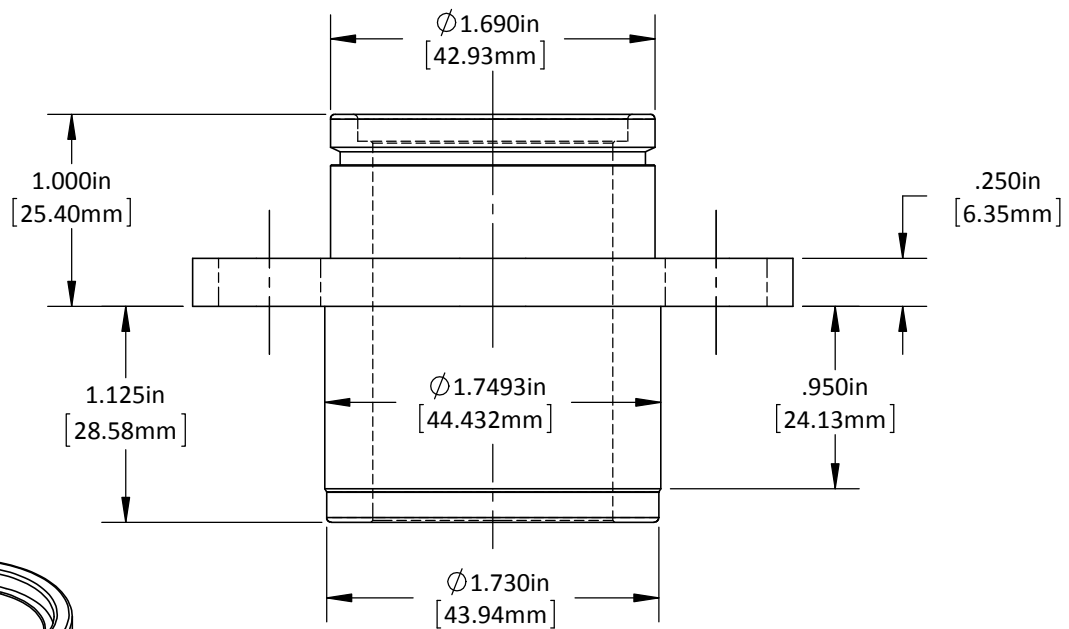
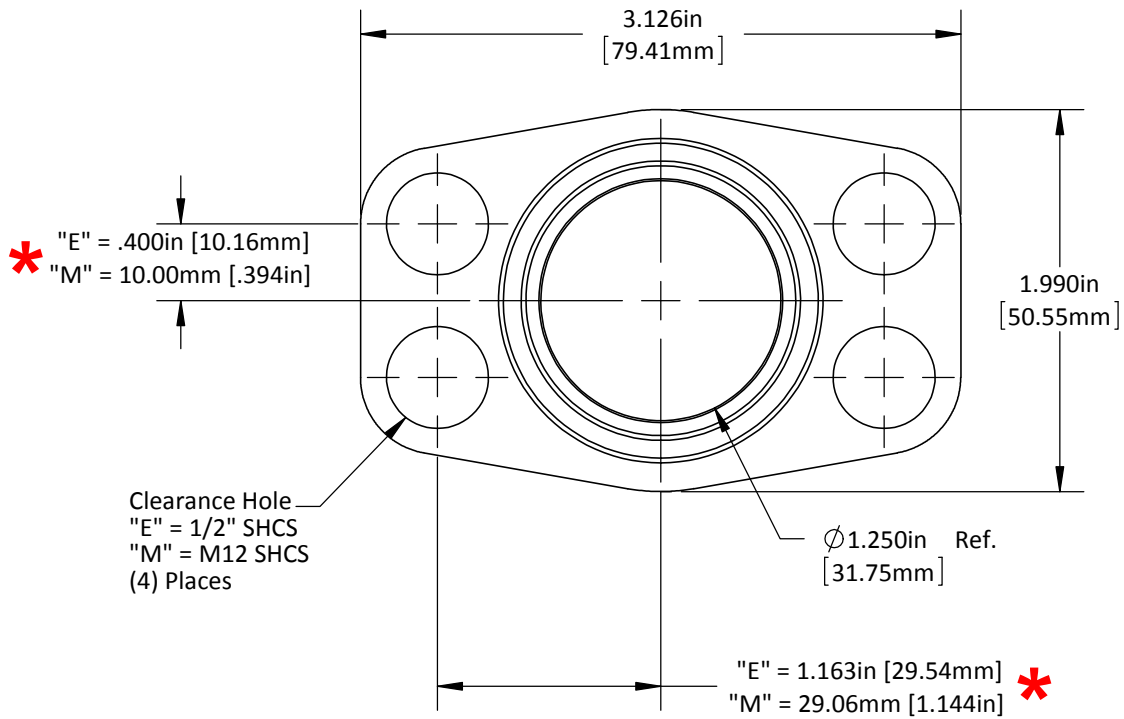

DO NOT SCALE DRAWING

REV 1

This product may be covered by one or more patents or patent applications.
 See <http://www.standardlifters.com/patents.html> for details.

Base-GK120-L2

STANDARD LIFTERS INC