

SECTION B-B

**Flush Mount Machining**

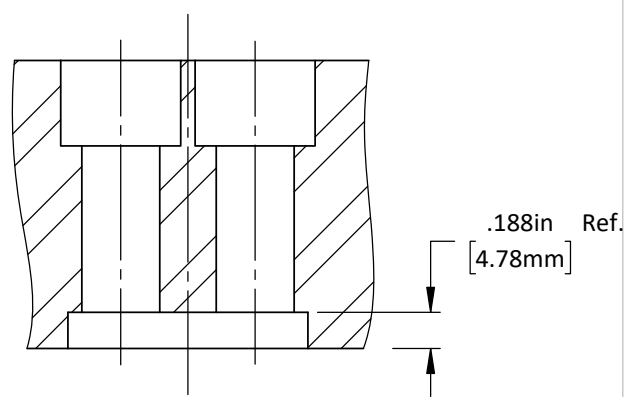

**Counterbore Mount Machining**

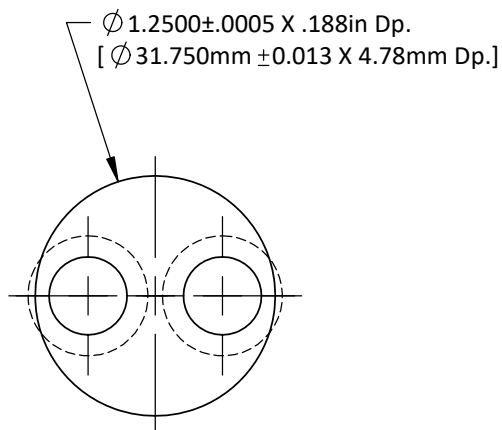

DO NOT SCALE DRAWING    REV 2

This product may be covered by one or more patents or patent applications.  
 See <http://www.standardlifters.com/patents.html> for details.

**Guide Pin GK120-Machining**

**Standard Lifters Inc**

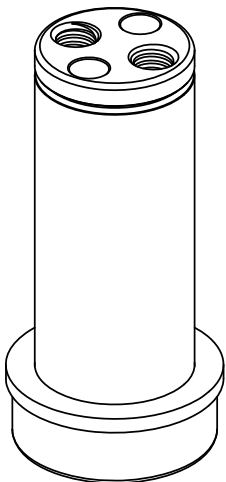
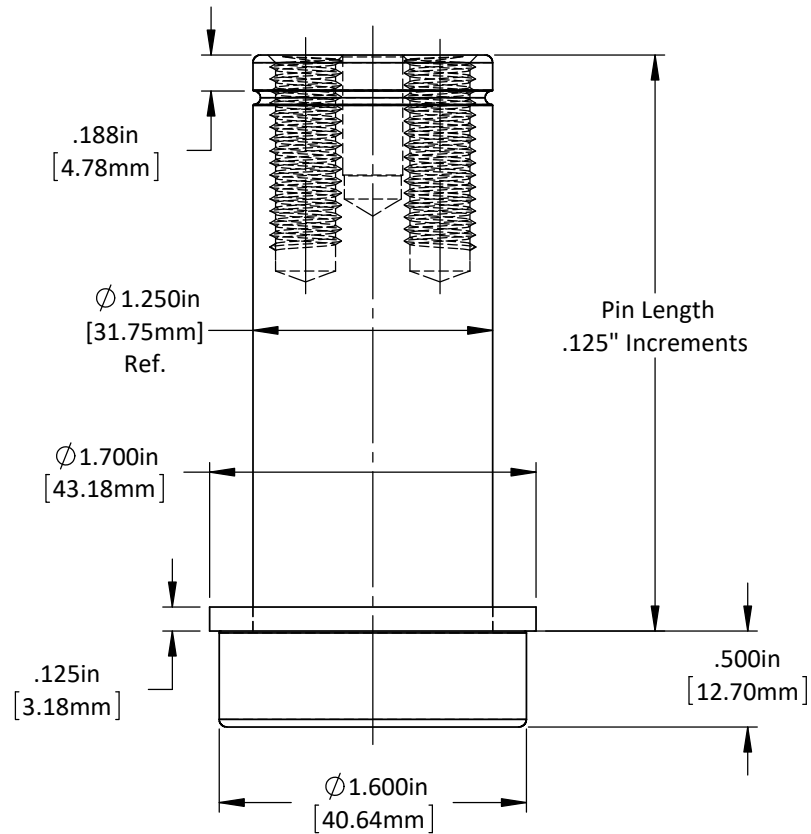
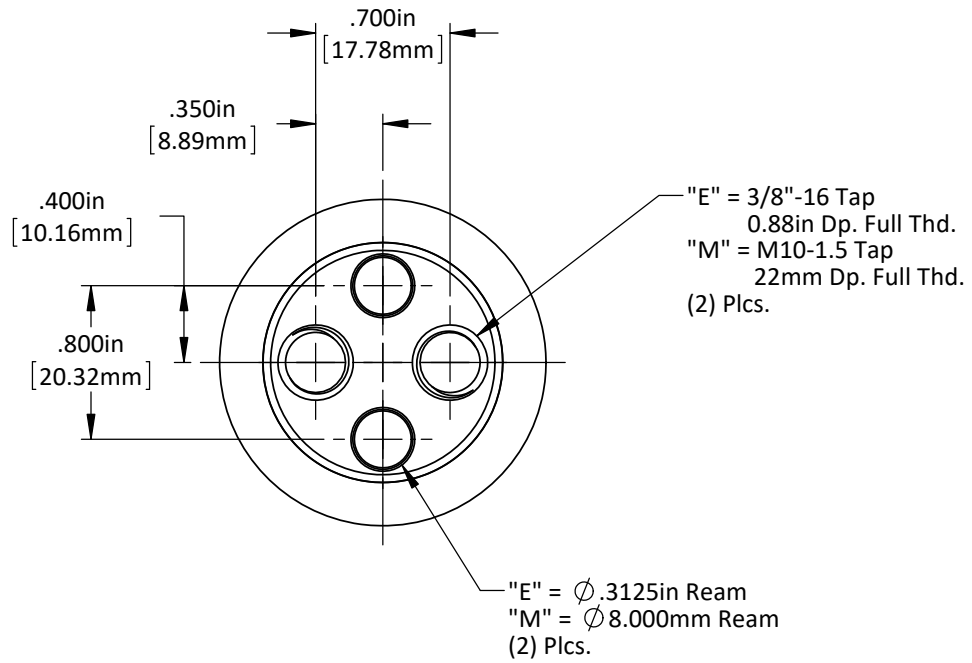

DO NOT SCALE DRAWING

REV 1

This product may be covered by one or more patents or  
 patent applications.  
 See <http://www.standardlifters.com/patents.html> for details.

**Guide Pin GK120**

**Standard Lifters Inc**