

Stock Guide Components

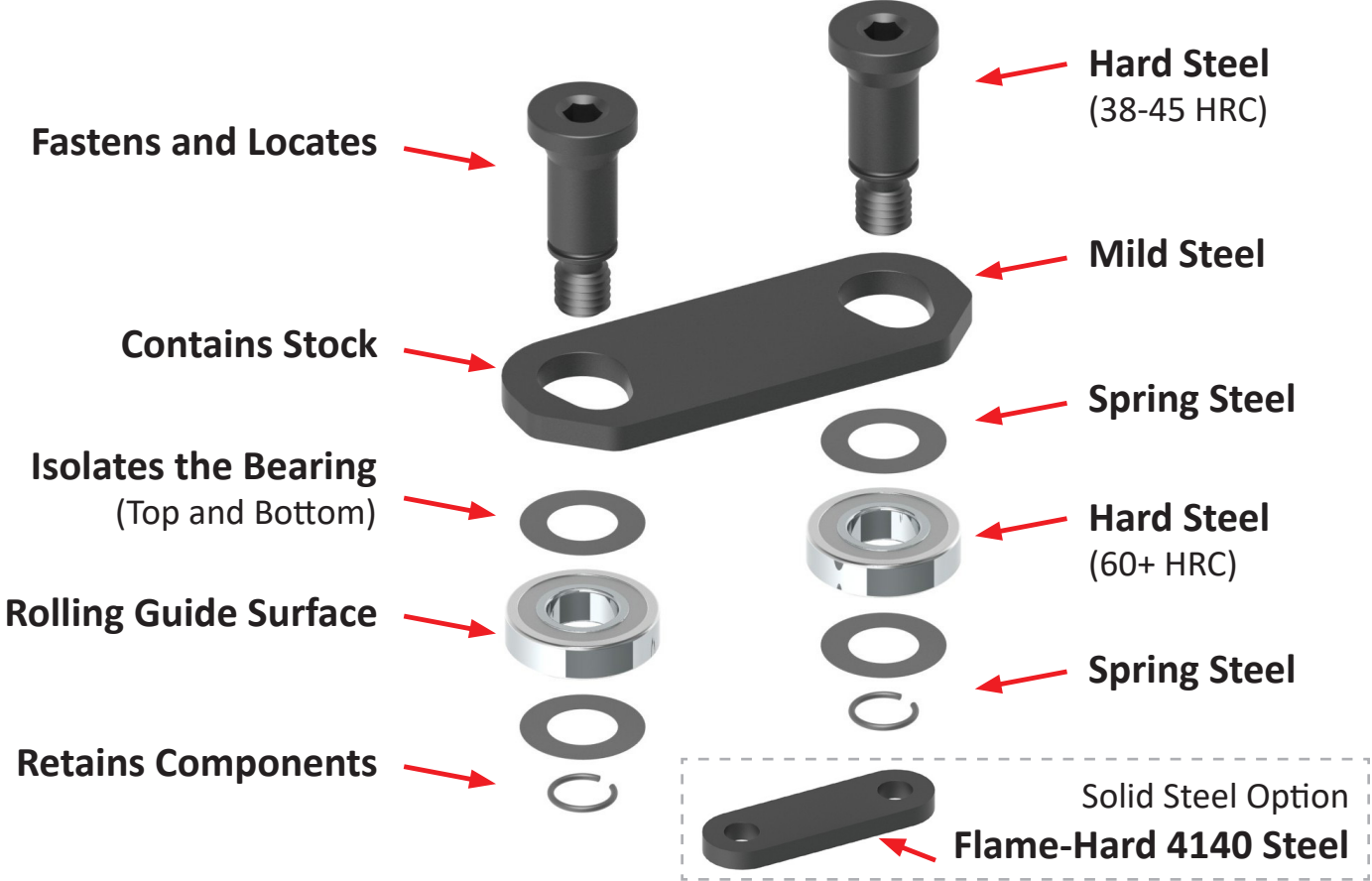

Machining

