

Pilots - Replacement Parts

P-F Style

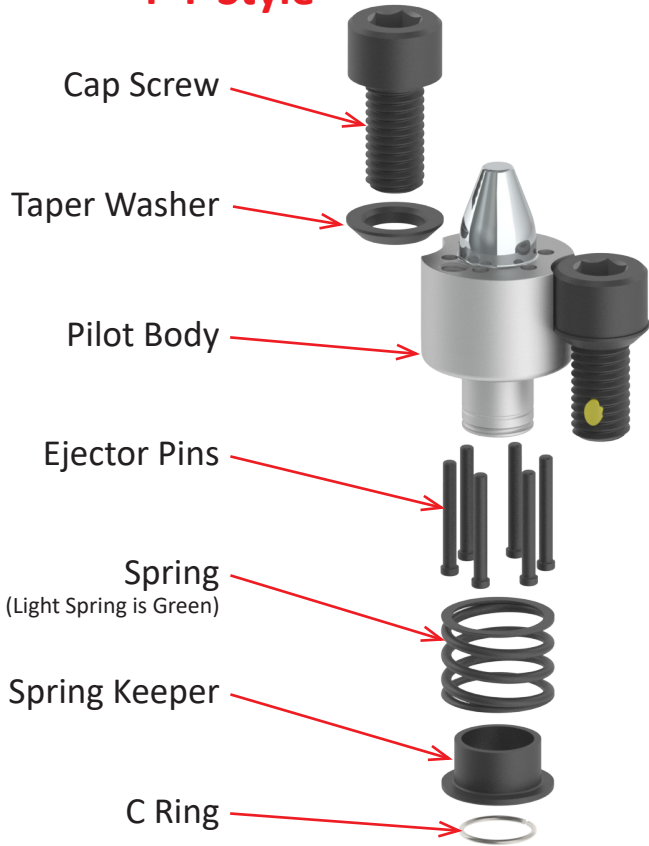

R-F Style



P-W Style

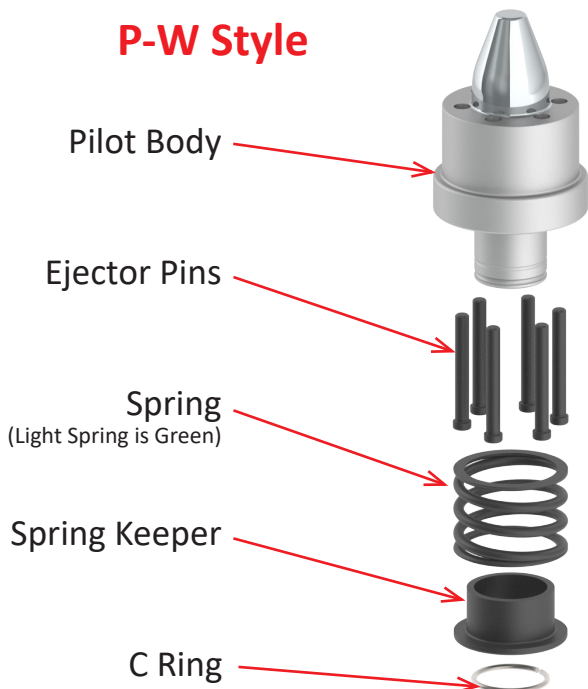

R-W Style

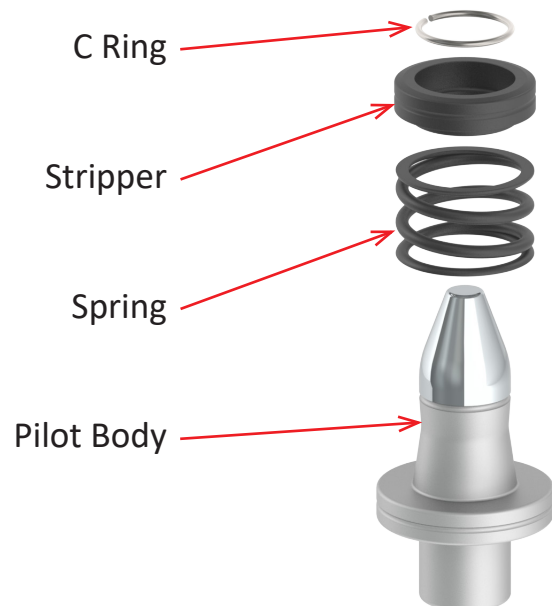

Pilots - Replacement Parts

When contacting SL for Replacement Parts please have the Product # and Date of Manufacture on hand, if possible. This is located on the bottom of the pilot assembly. This will help to ensure SL ships you the exact parts you need.



	<p>Ejector Pins</p>	<p>English and Metric: Ejector-09-.740Long</p>
	<p>Patched Fasteners</p>	<p>Metric: CapScrew-Standard-Patched-M10_1.5-20mm English: CapScrew-Standard-Patched-.375_16-.75</p>
	<p>Washers</p>	<p>Metric: TaperWasher-PA-M English: TaperWasher-PA-E</p>
	<p>Springs</p>	<p>For Standard or Light Force Springs contact SL with Assembly Product # and what Part(s) you need</p>
	<p>Other Misc Parts</p>	<p>For Crings, Spring Keepers, Round Strippers, and Flanges contact SL with Assembly Product # and what Part(s) you need</p>
	<p>Legacy Products</p>	<p>For High Collar Lock Washers, Erings, and other parts on Old Legacy Products contact SL with Assembly Product # and what Part(s) you need (pictures can also be helpful)</p>

