

DO NOT SCALE DRAWING	REV 1
This product may be covered by one or more patents or patent applications. See http://www.standardlifters.com/patents.html for details.	

Guide Pin GK200-Machining
Standard Lifters Inc

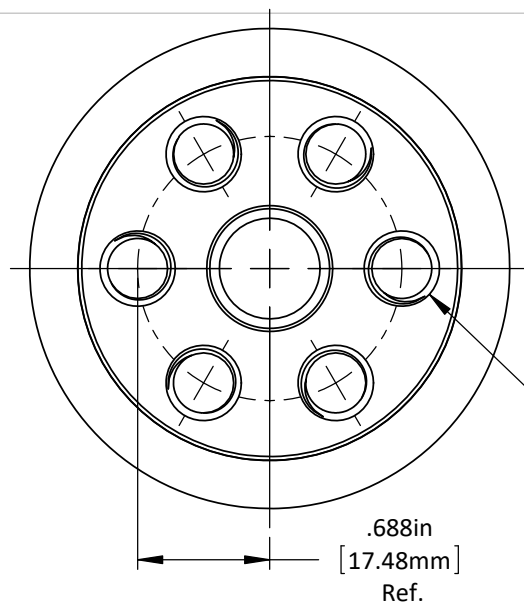

"E" = 3/8-16 Tap
 0.88" Dp. Full Thd.
 "M" = M10-1.5 Tap
 22mm Dp. Full Thd.
 (6) Places Equally Spaced
 On a ϕ 1.376" [34.95mm]
 Bolt Circle

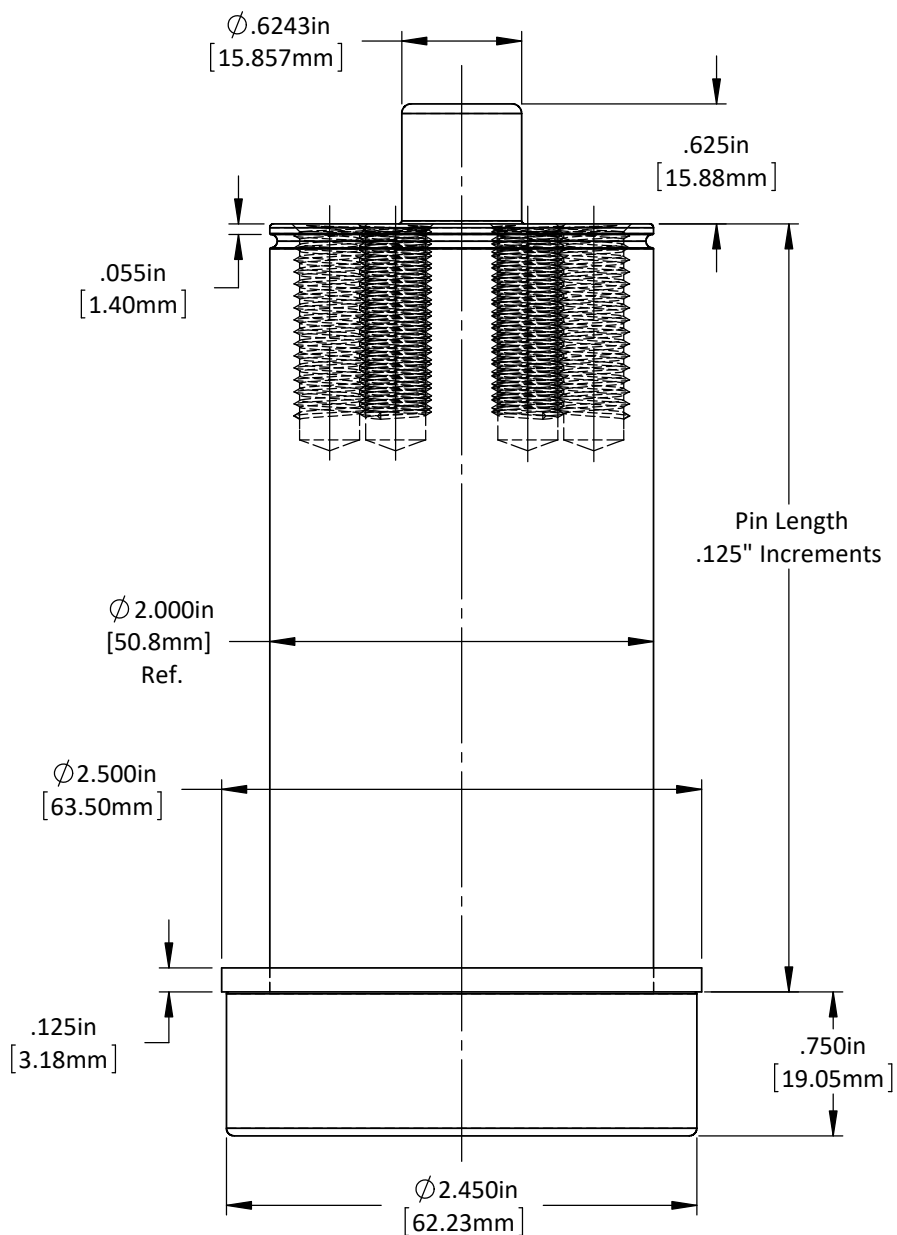

Pin Length
 .125" Increments

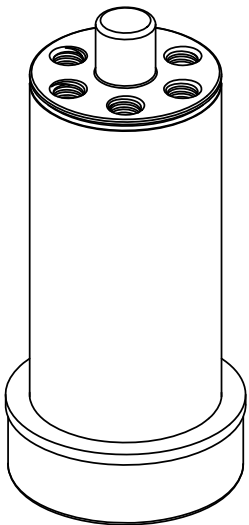

DO NOT SCALE DRAWING

REV 1

This product may be covered by one or more patents or patent applications.
 See <http://www.standardlifters.com/patents.html> for details.

Guide Pin GK200

Standard Lifters Inc