

***Caution: English & Metric Hole Locations are NOT the Same!**

* "E" = .400in [10.16mm]
"M" = 10.00mm [.394in]

"E" = 1.357in [34.47mm] *
"M" = 34.00mm [1.338in] *

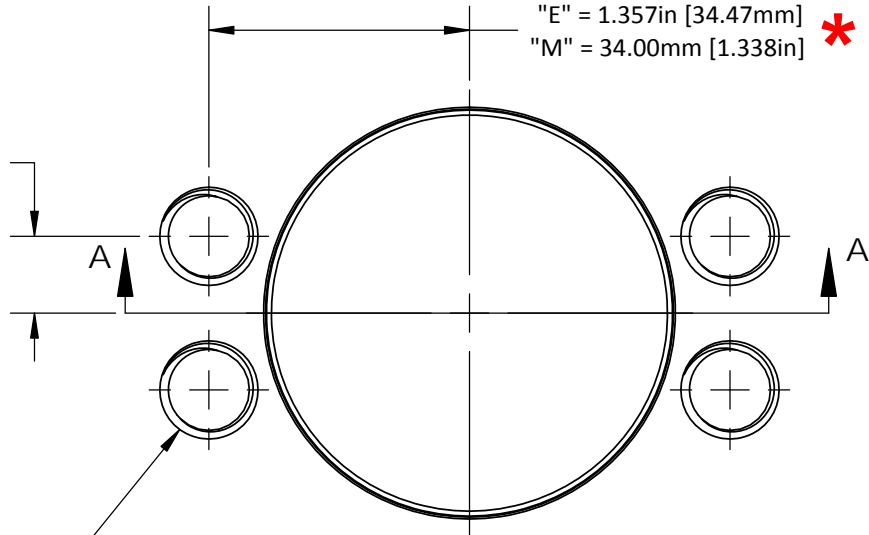

"E" = 1/2"-13 Tap
"M" = M12-1.75 Tap
(4) Places

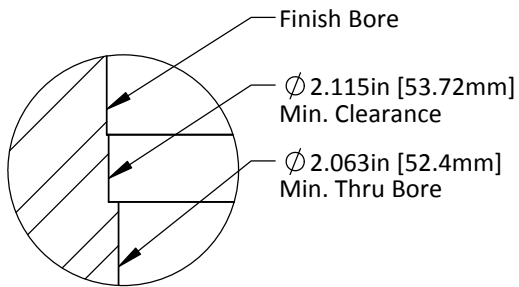

DETAIL C
SCALE 2 : 1

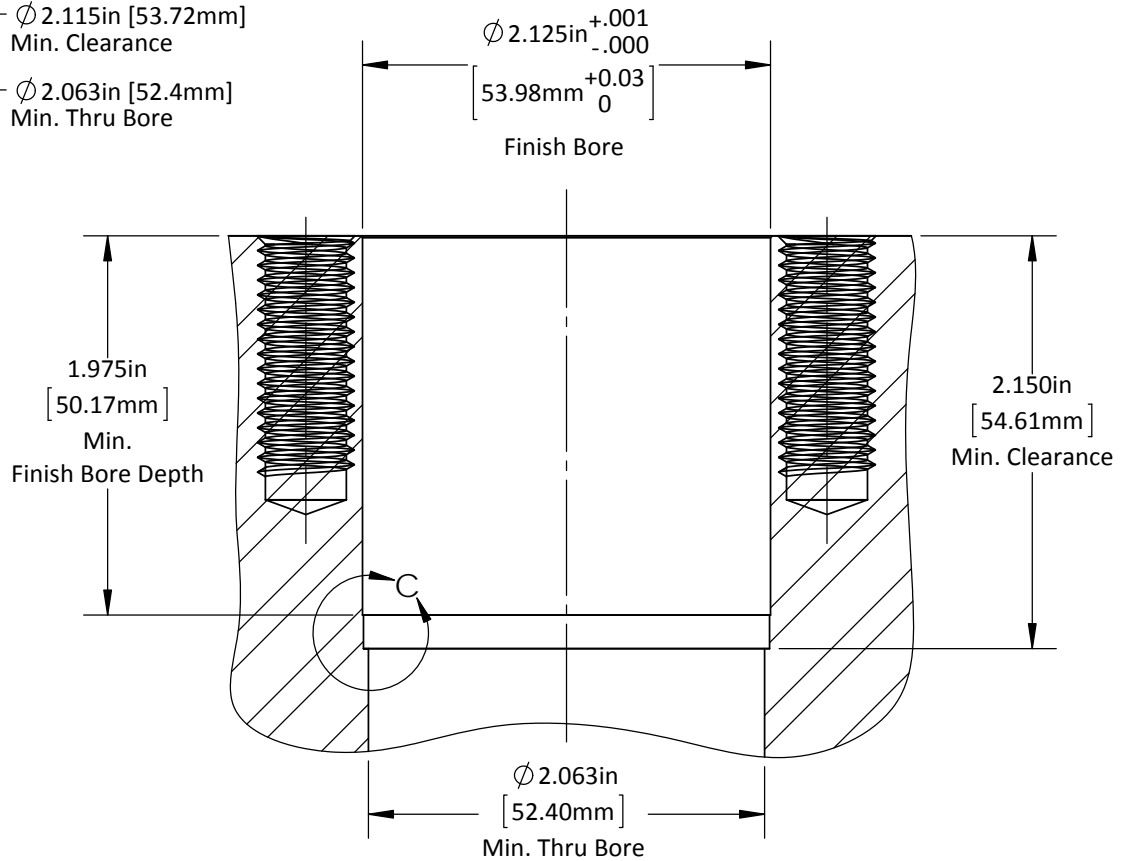

DO NOT SCALE DRAWING

REV 2

This product may be covered by one or more patents or patent applications.
See <http://www.standardlifters.com/patents.html> for details.

GK150-L3-Base Machining

STANDARD LIFTERS INC

***Caution: English & Metric Hole Locations are NOT the Same!**

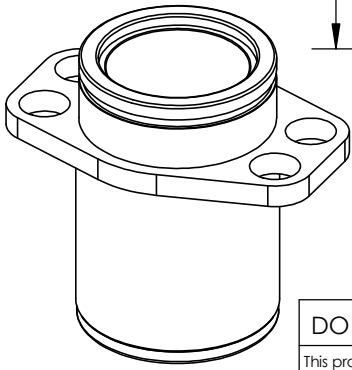
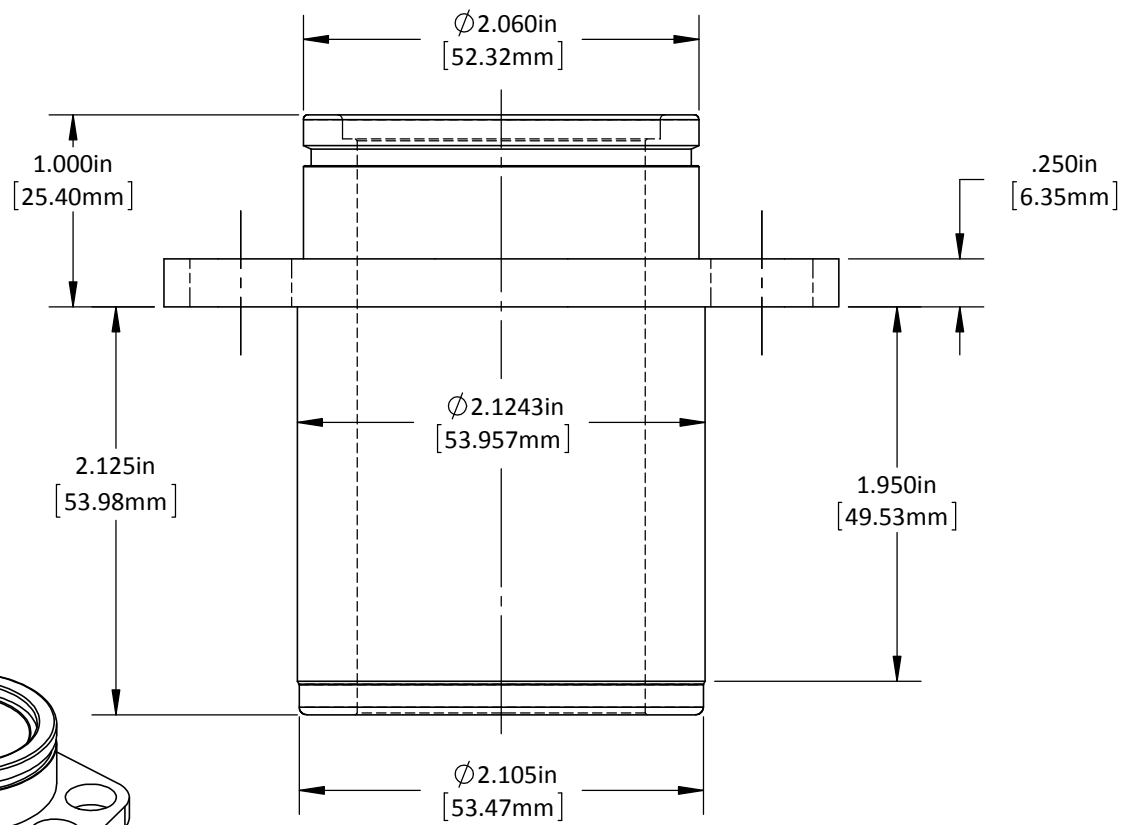
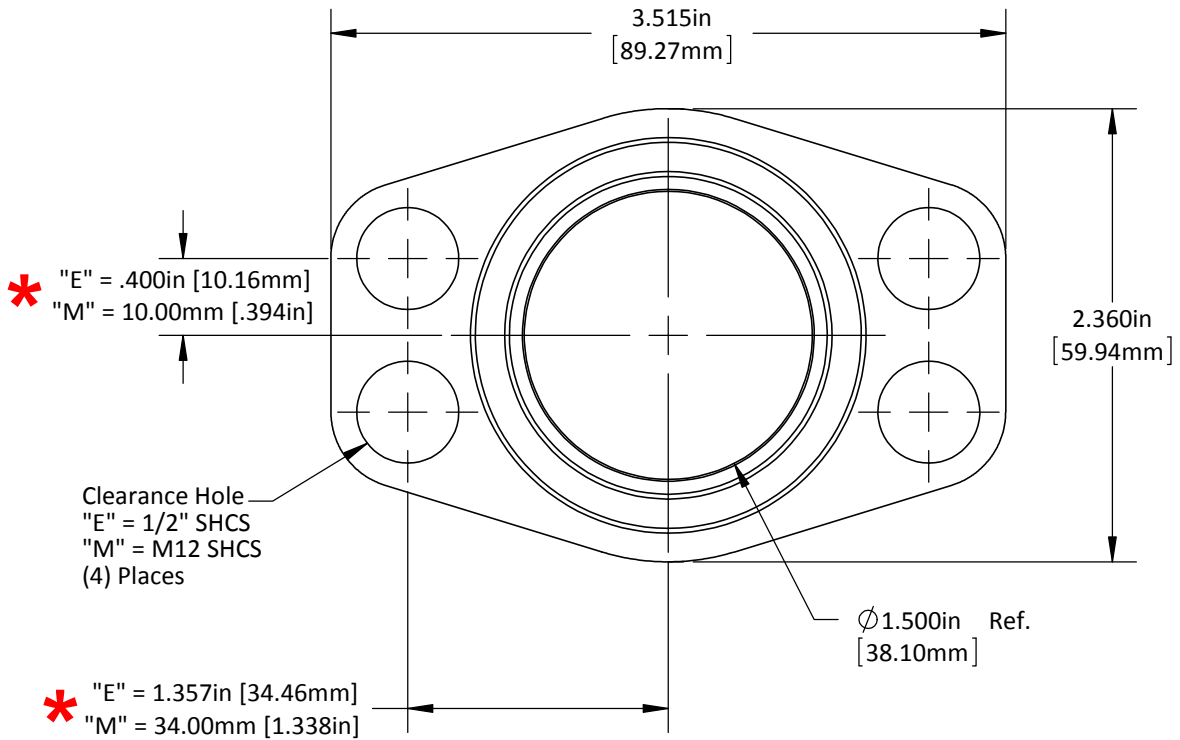

DO NOT SCALE DRAWING REV 1

This product may be covered by one or more patents or patent applications.
 See <http://www.standardlifters.com/patents.html> for details.

Base-GK150-L3

STANDARD LIFTERS INC