

SECTION A-A

DO NOT SCALE DRAWING

REV 1

This product may be covered by one or more patents or patent applications.  
See <http://www.standardlifters.com/patents.html> for details.

**SE-1.00-.188-S-A-Machining**

**STANDARD LIFTERS INC**

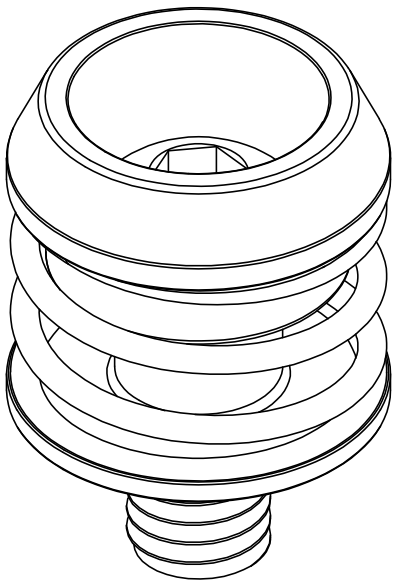
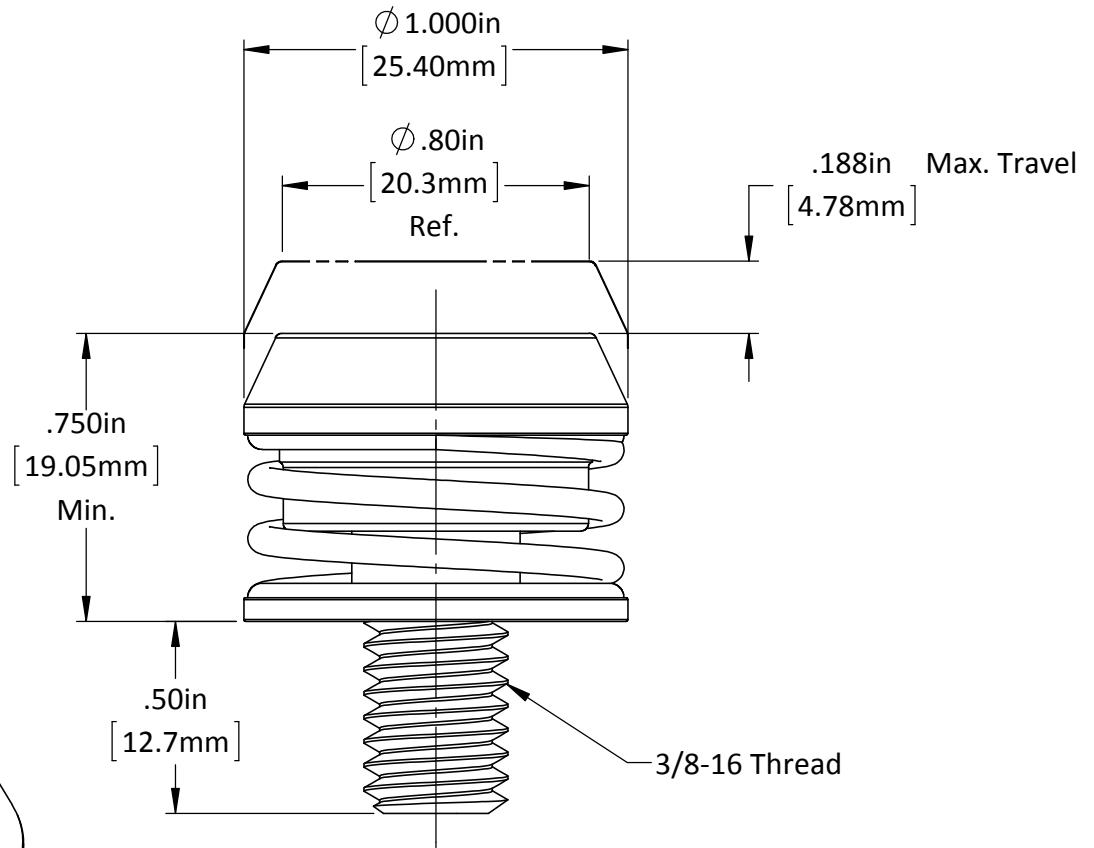
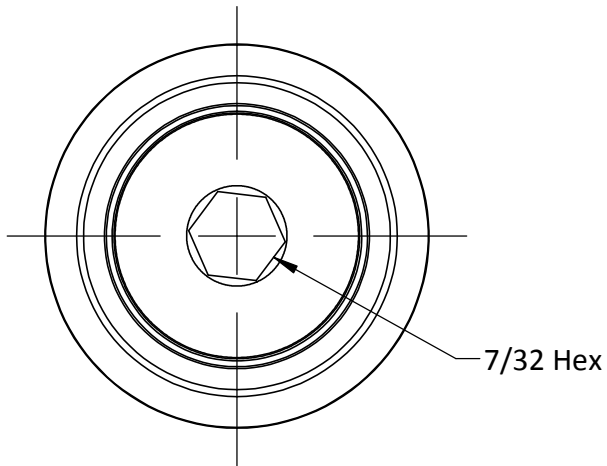

DO NOT SCALE DRAWING    REV 1  
This product may be covered by one or more patents or patent applications.  
See <http://www.standardlifters.com/patents.html> for details.

**SE-1.00-.188-S-A**  
**STANDARD LIFTERS INC**