

R.035in Max.
[0.9mm]

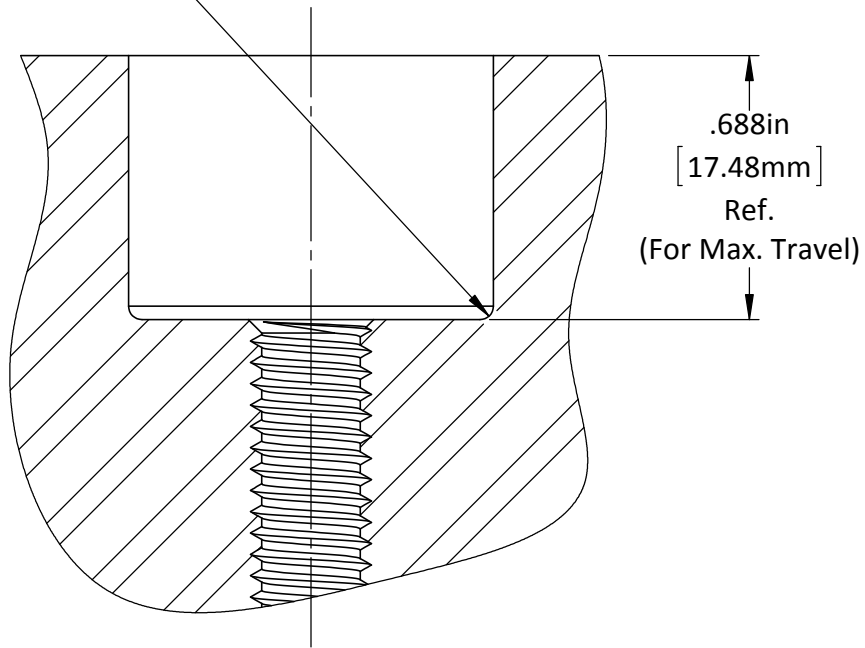

SECTION A-A

DO NOT SCALE DRAWING

REV 1

This product may be covered by one or more patents or patent applications.
See <http://www.standardlifters.com/patents.html> for details.

SE-.875-.156-S-A-Machining

STANDARD LIFTERS INC

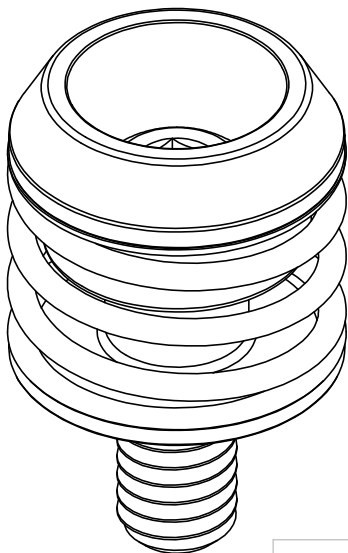
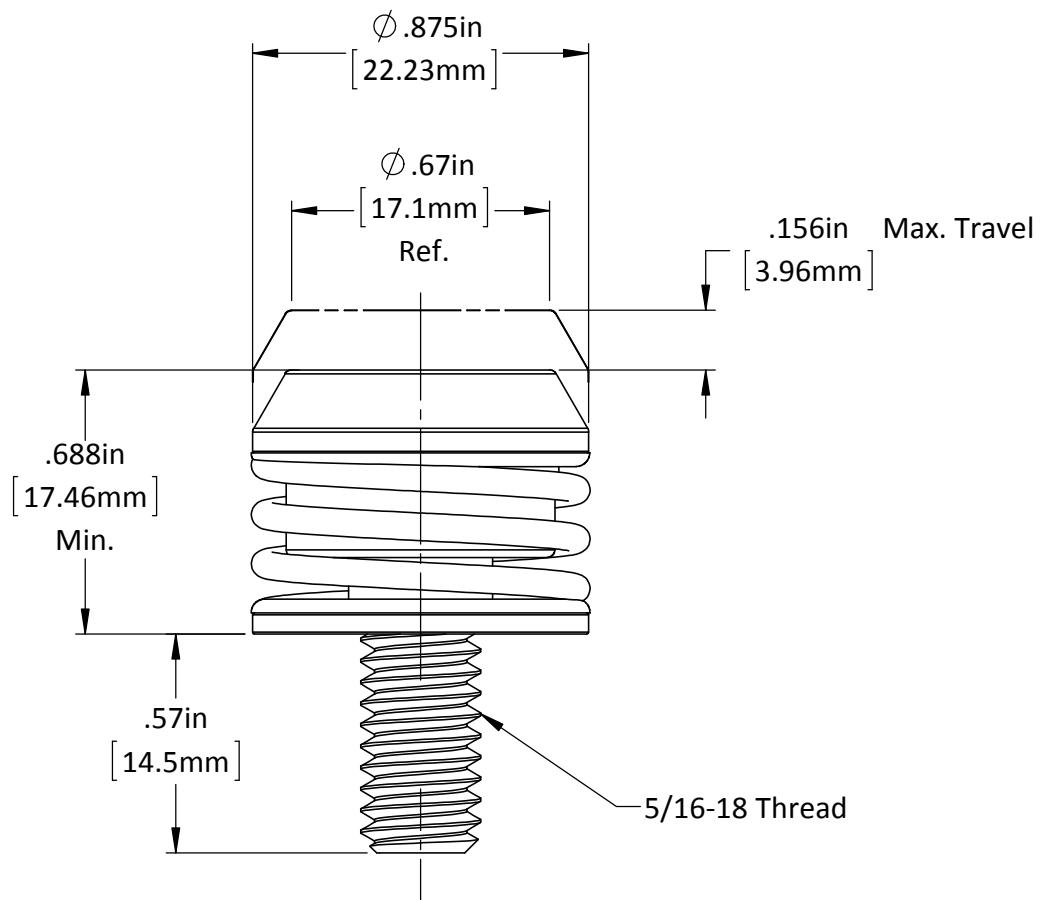
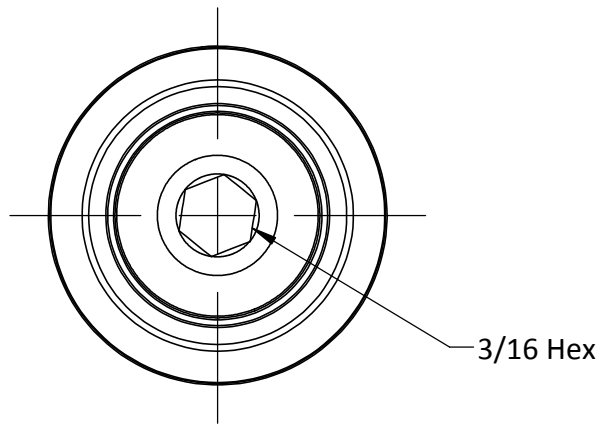

DO NOT SCALE DRAWING REV 1

This product may be covered by one or more patents or patent applications.
See <http://www.standardlifters.com/patents.html> for details.

SE-.875-.156-S-A

STANDARD LIFTERS INC