

SECTION A-A

DO NOT SCALE DRAWING	REV 1	Pilot-PA-T-20mm-3.8mm-F-Machining
This product may be covered by one or more patents or patent applications. See http://www.standardlifters.com/patents.html for details.		

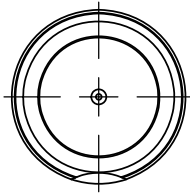

1 Hold Down

PA-T-20mm-3.8mm-75mm-3-A-F₁

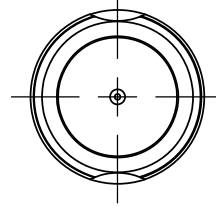

2 Hold Downs

PA-T-20mm-3.8mm-75mm-3-A-F₂

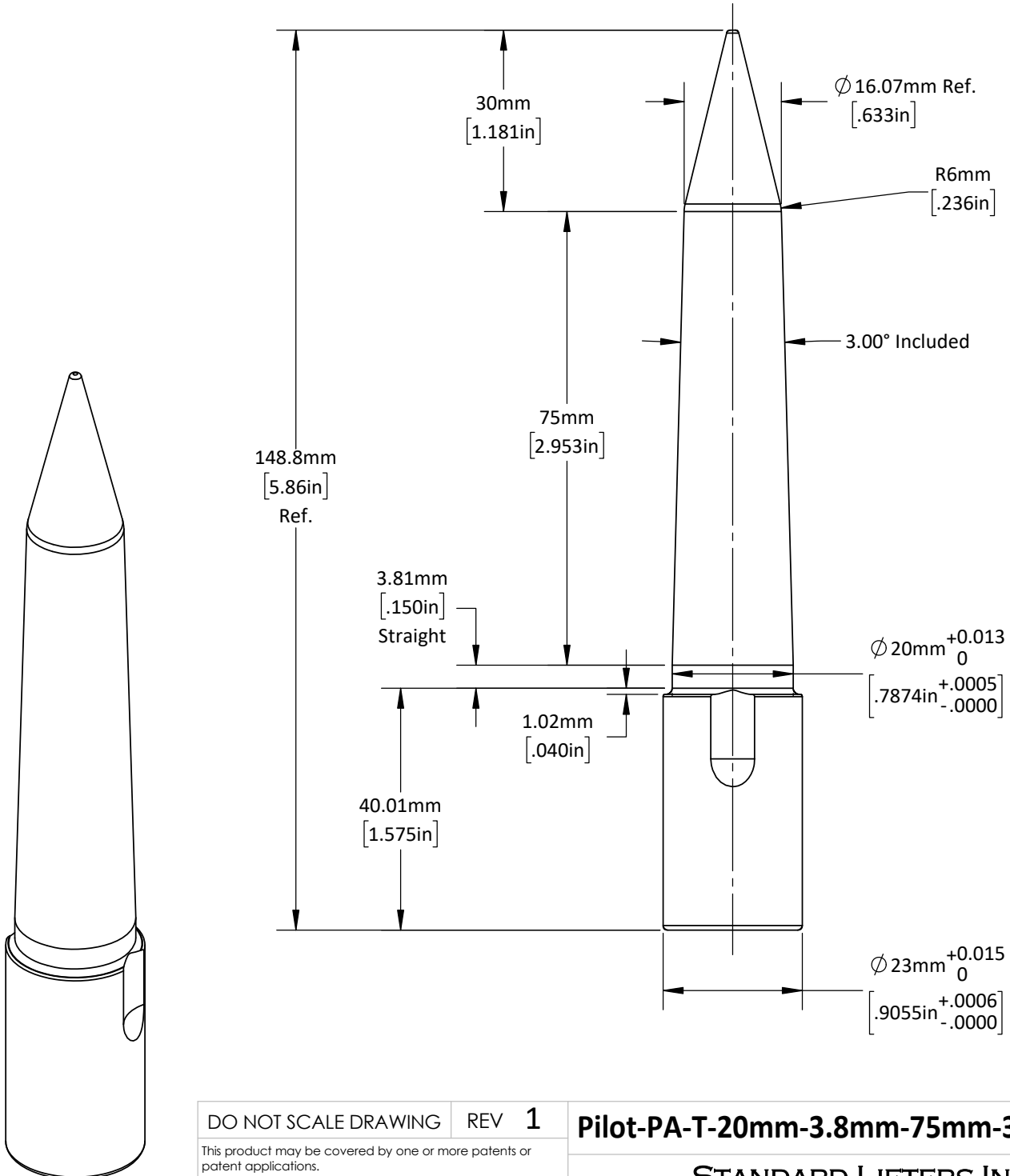

DO NOT SCALE DRAWING

REV 1

Pilot-PA-T-20mm-3.8mm-75mm-3-A-F₁ / F₂

This product may be covered by one or more patents or patent applications.
See <http://www.standardlifters.com/patents.html> for details.

STANDARD LIFTERS INC