

**1 Hold Down**

**PA-T-20mm-3.8mm-50mm-3-A-F<sub>1</sub>**

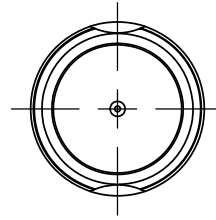

**2 Hold Downs**

**PA-T-20mm-3.8mm-50mm-3-A-F<sub>2</sub>**

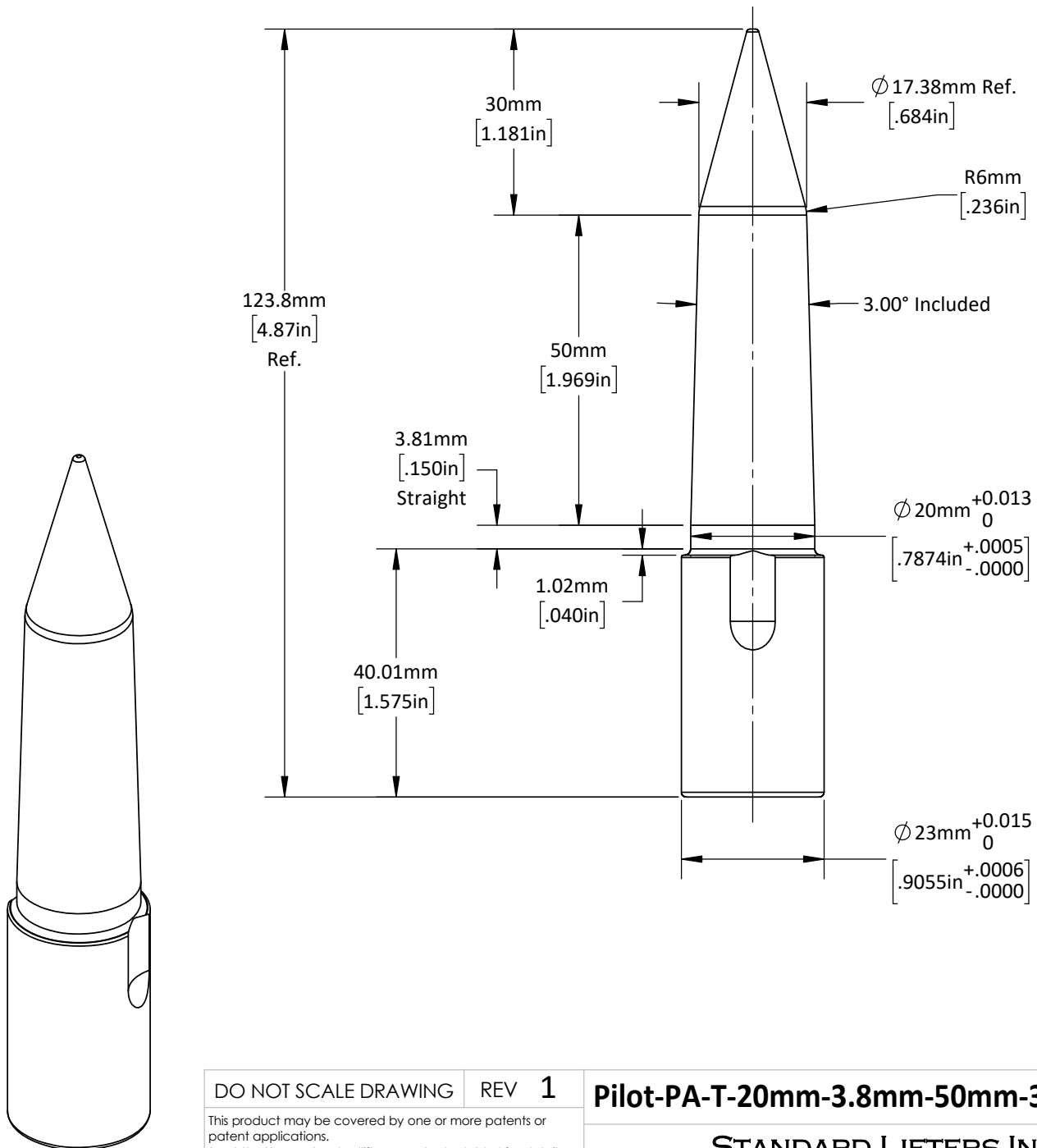

DO NOT SCALE DRAWING

REV 1

**Pilot-PA-T-20mm-3.8mm-50mm-3-A-F<sub>1</sub> / F<sub>2</sub>**

This product may be covered by one or more patents or patent applications.  
See <http://www.standardlifters.com/patents.html> for details.

**STANDARD LIFTERS INC**