

SECTION A-A

DO NOT SCALE DRAWING	REV 1	<b>Pilot-PA-T-20mm-3.8mm-F-Machining</b>
This product may be covered by one or more patents or patent applications. See <a href="http://www.standardlifters.com/patents.html">http://www.standardlifters.com/patents.html</a> for details.		

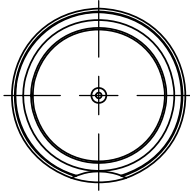

**1 Hold Down**  
**PA-T-20mm-3.8mm-40mm-3-A-F1**

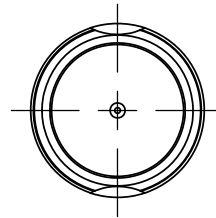

**2 Hold Downs**  
**PA-T-20mm-3.8mm-40mm-3-A-F2**

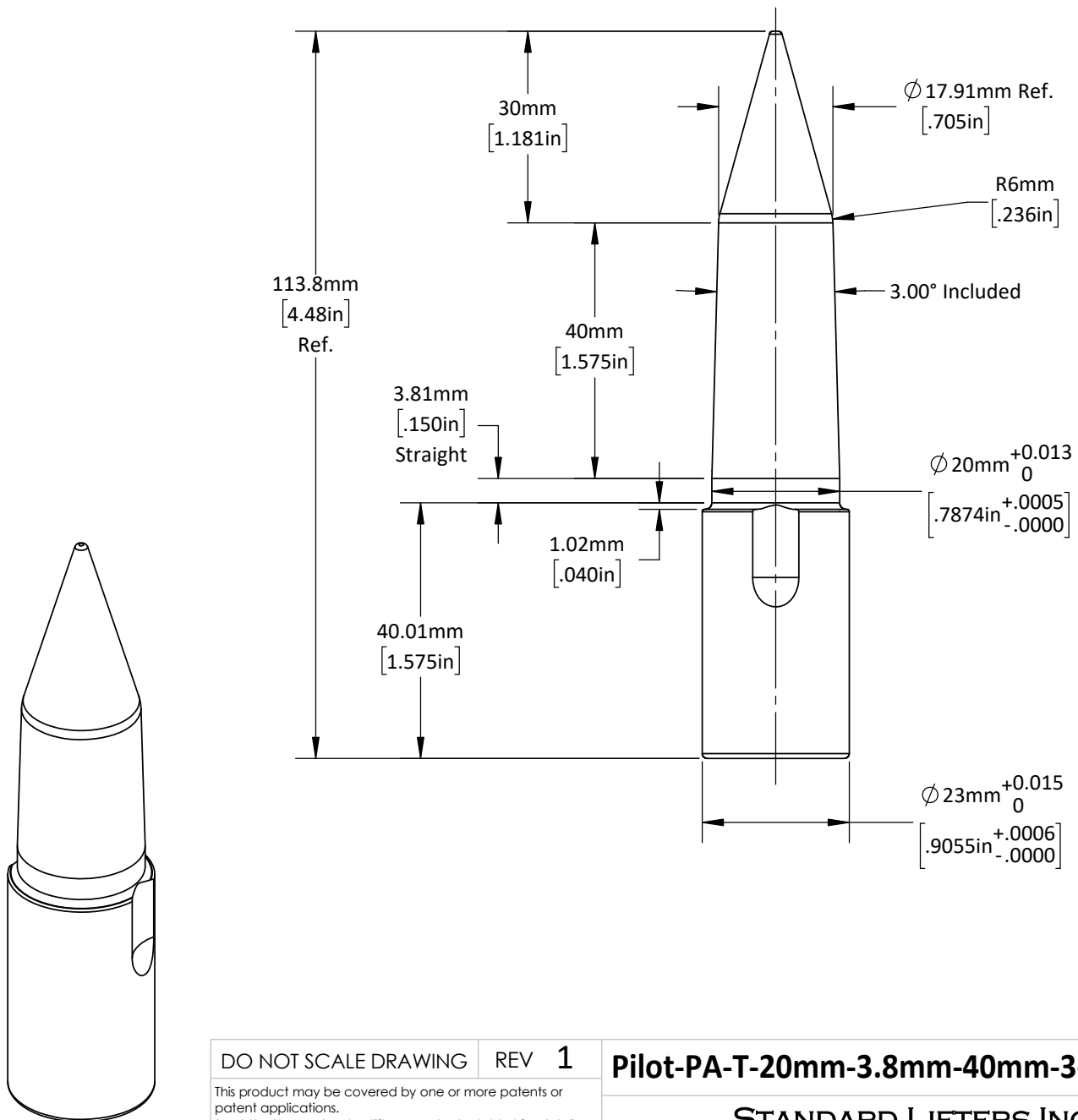

DO NOT SCALE DRAWING    REV 1  
 This product may be covered by one or more patents or patent applications.  
 See <http://www.standardlifters.com/patents.html> for details.

**Pilot-PA-T-20mm-3.8mm-40mm-3-A-F1 / F2**  
**STANDARD LIFTERS INC**