

DO NOT SCALE DRAWING REV 1

This product may be covered by one or more patents or patent applications.
 See <http://www.standardlifters.com/patents.html> for details.

Pilot-PA-T-20mm-3.8mm-F-Machining

STANDARD LIFTERS INC

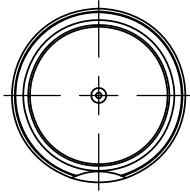

1 Hold Down

PA-T-20mm-3.8mm-25mm-3-A-F1

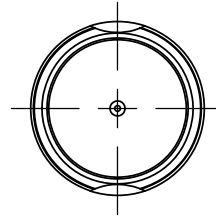

2 Hold Downs

PA-T-20mm-3.8mm-25mm-3-A-F2

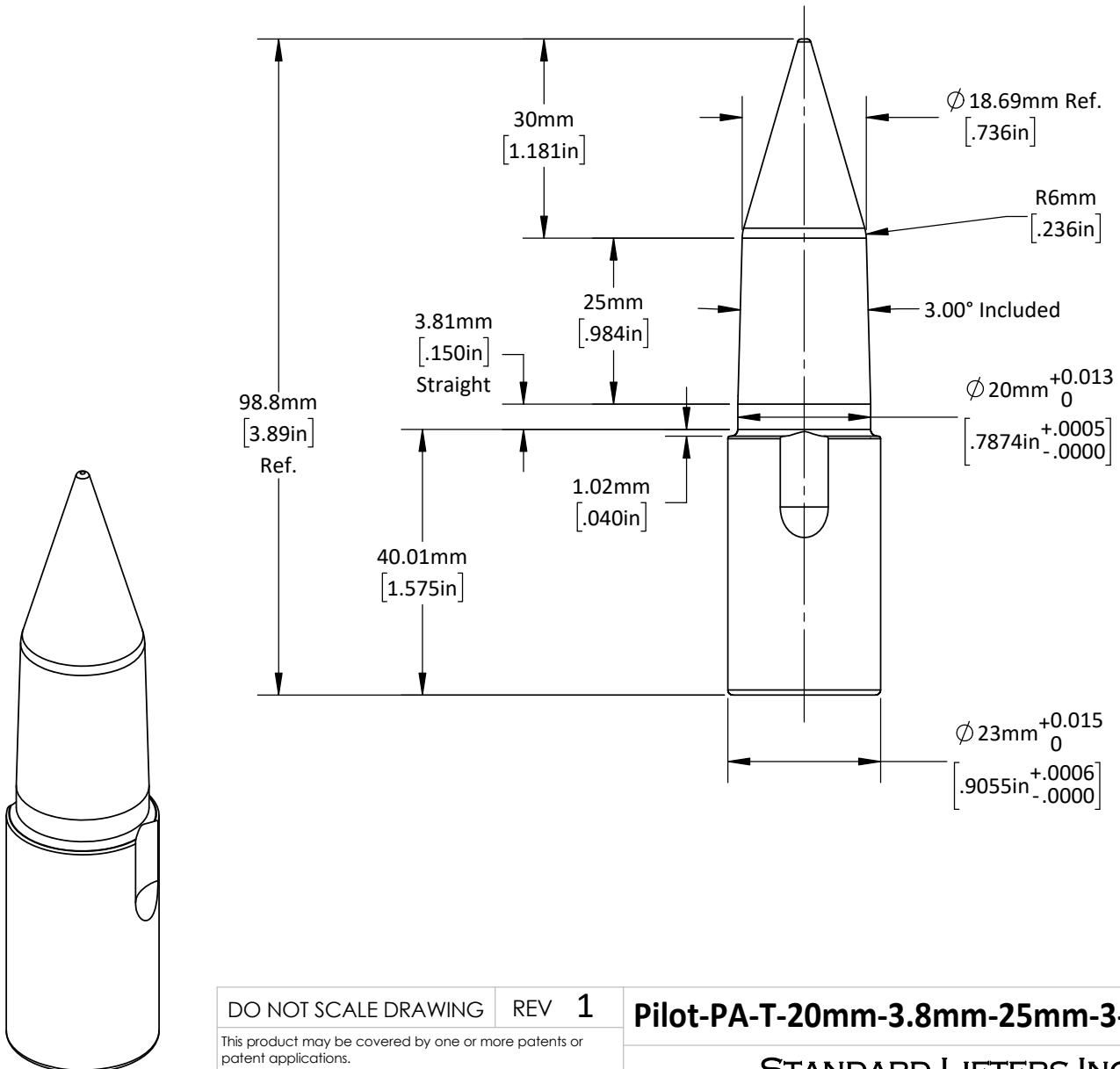

DO NOT SCALE DRAWING REV 1

This product may be covered by one or more patents or patent applications. See <http://www.standardlifters.com/patents.html> for details.

Pilot-PA-T-20mm-3.8mm-25mm-3-A-F1 / F2

STANDARD LIFTERS INC