

Ø 12mm Drill Thru
[.472in]

16.10mm
[.634in]

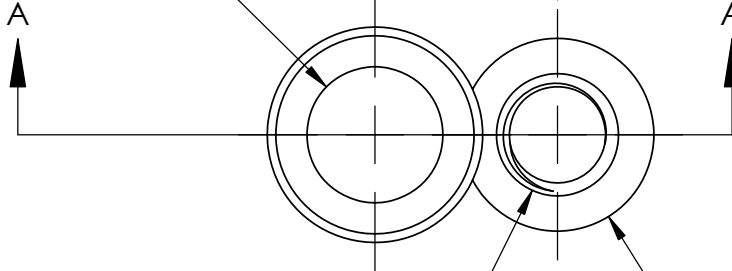

Ø 17mm±0.25
[.669in±.010]

M10-1.5 Tap

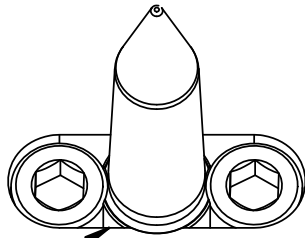

Do Not Slot Fastener Holes
Slotting the Fastener Pocket
Reduces Support to the Pilot Body

Ø 19mm^{+0.021}₀
[.7480in^{+0.0008}_{-.0000}]

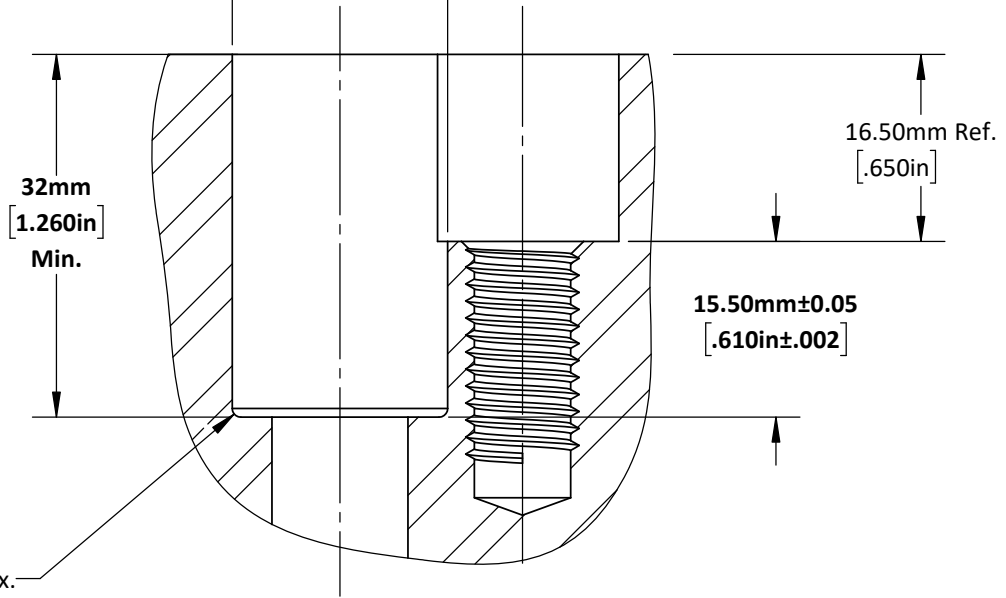

SECTION A-A

DO NOT SCALE DRAWING

REV 1

Pilot-PA-T-16mm-3.2mm-F-Machining

This product may be covered by one or more patents or patent applications.
See <http://www.standardlifters.com/patents.html> for details.

STANDARD LIFTERS INC

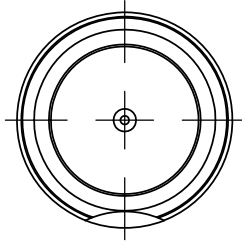

1 Hold Down

PA-T-16mm-3.2mm-65mm-3-A-F1

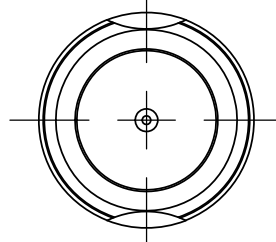

2 Hold Downs

PA-T-16mm-3.2mm-65mm-3-A-F2

