

Ø 10mm Drill Thru
[.394in]

14.61mm
[.575in]

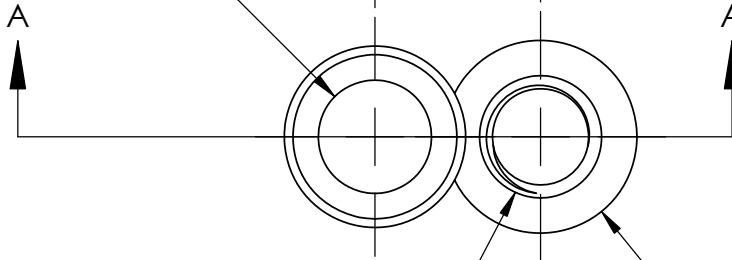

Ø 17mm±0.25
[.669in±.010]

M10-1.5 Tap

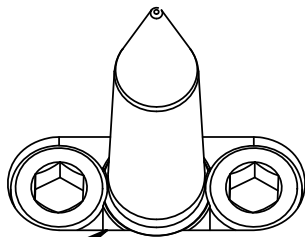

Do Not Slot Fastener Holes
Slotting the Fastener Pocket
Reduces Support to the Pilot Body

Ø 15.999mm^{+0.018}₀
[.6299in^{+0.0007}_{-.0000}]

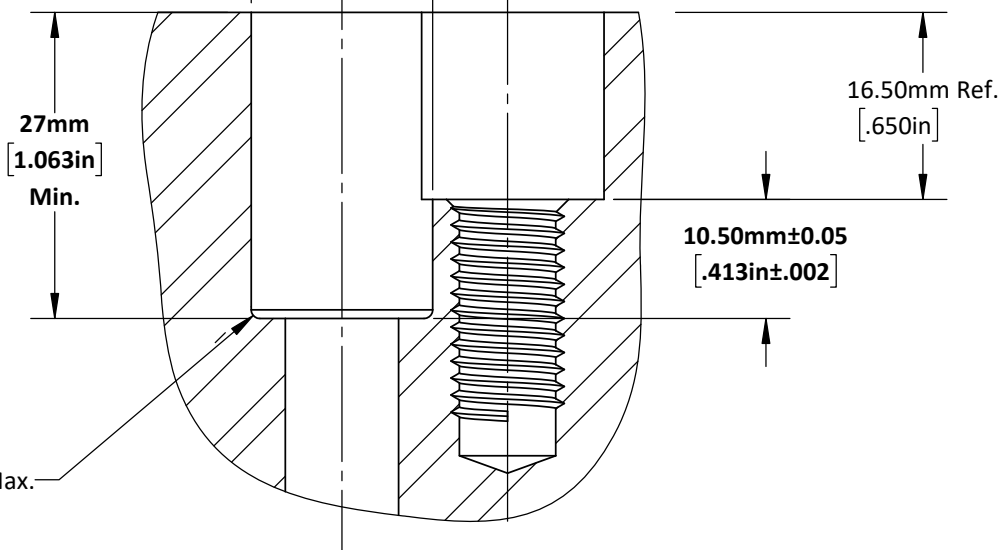

SECTION A-A

DO NOT SCALE DRAWING

REV 1

Pilot-PA-T-13mm-2.5mm-F-Machining

This product may be covered by one or more patents or patent applications.
See <http://www.standardlifters.com/patents.html> for details.

STANDARD LIFTERS INC

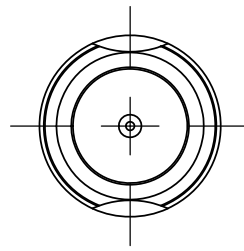
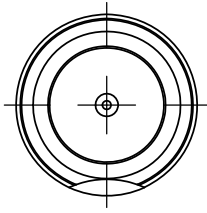

1 Hold Down

PA-T-13mm-2.5mm-50mm-3-A-F₁

2 Hold Downs

PA-T-13mm-2.5mm-50mm-3-A-F₂

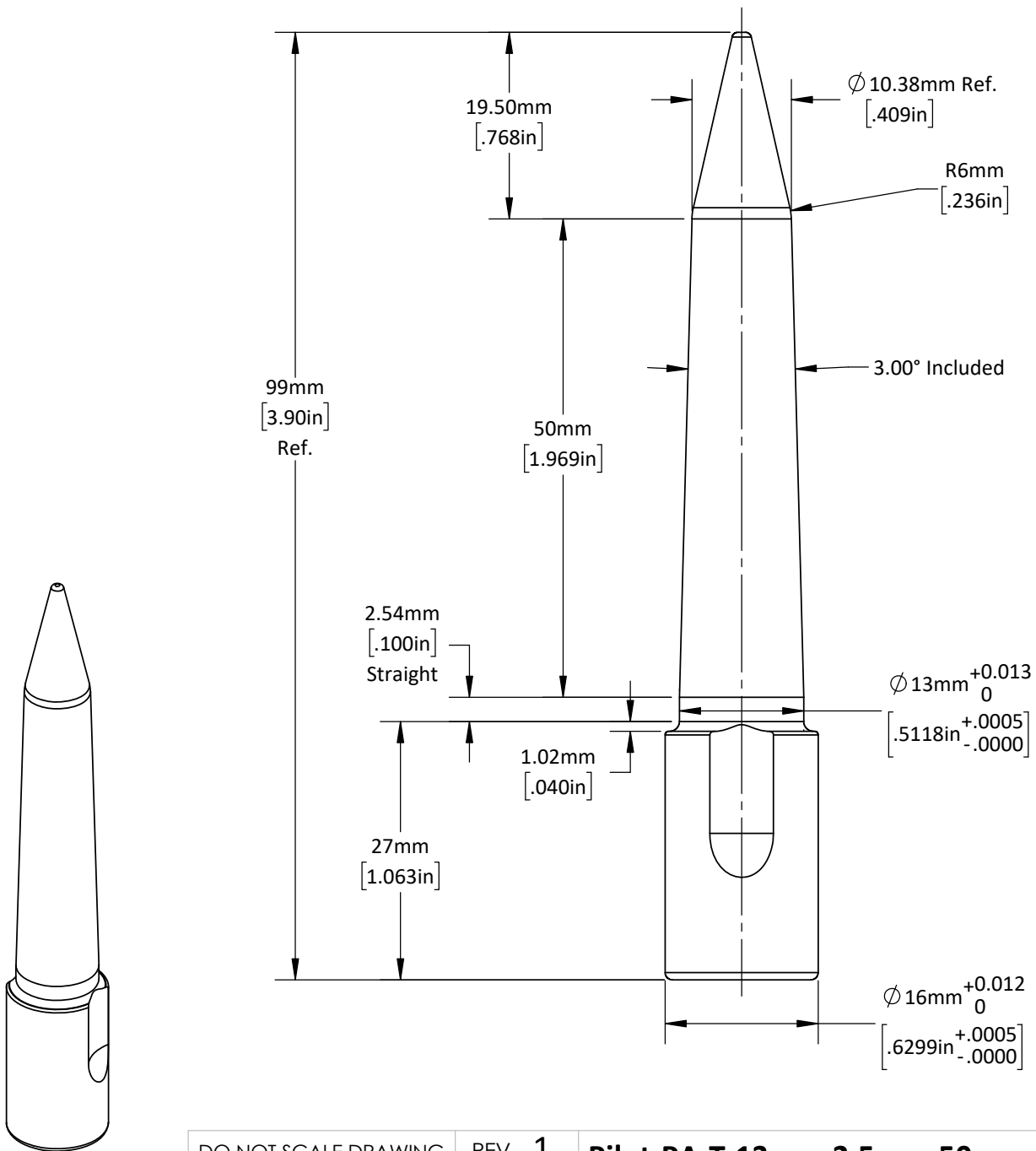

DO NOT SCALE DRAWING

REV 1

Pilot-PA-T-13mm-2.5mm-50mm-3-A-F₁ / F₂

This product may be covered by one or more patents or patent applications.
See <http://www.standardlifters.com/patents.html> for details.

STANDARD LIFTERS INC