

Ø 6mm Drill Thru
[.236in]

13.10mm
[.516in]

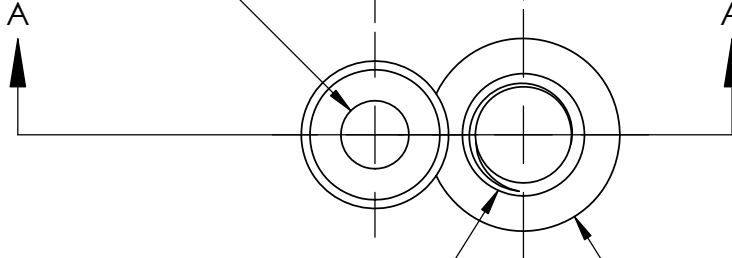

M10-1.5 Tap

Ø 17mm±0.25
[.669in±.010]

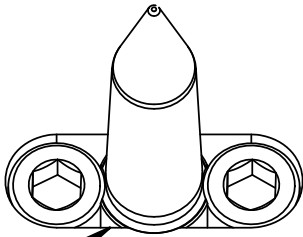

Do Not Slot Fastener Holes
Slotting the Fastener Pocket
Reduces Support to the Pilot Body

Ø 13mm^{+0.018}₀
[.5118in^{+0.0007}_{-.0000}]

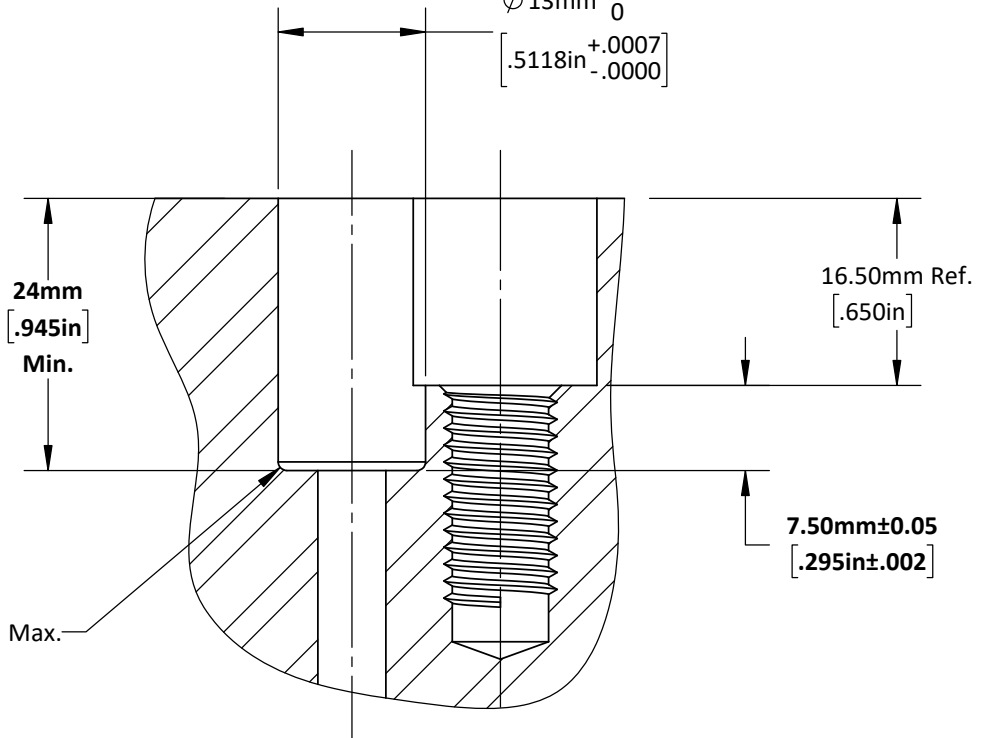

R0.76mm Max.
[.030in]

24mm
[.945in]
Min.

16.50mm Ref.
[.650in]

7.50mm±0.05
[.295in±.002]

SECTION A-A

DO NOT SCALE DRAWING

REV 1

This product may be covered by one or more patents or patent applications. See <http://www.standardlifters.com/patents.html> for details.

Pilot-PA-T-10mm-1.9mm-F-Machining

STANDARD LIFTERS INC

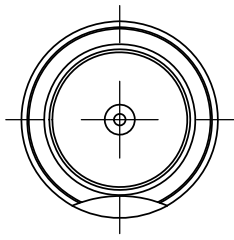

1 Hold Down
PA-T-10mm-1.9mm-25mm-3-A-F₁

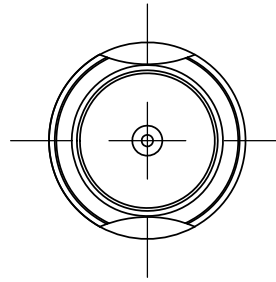

2 Hold Downs
PA-T-10mm-1.9mm-25mm-3-A-F₂

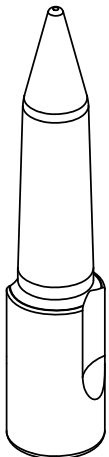
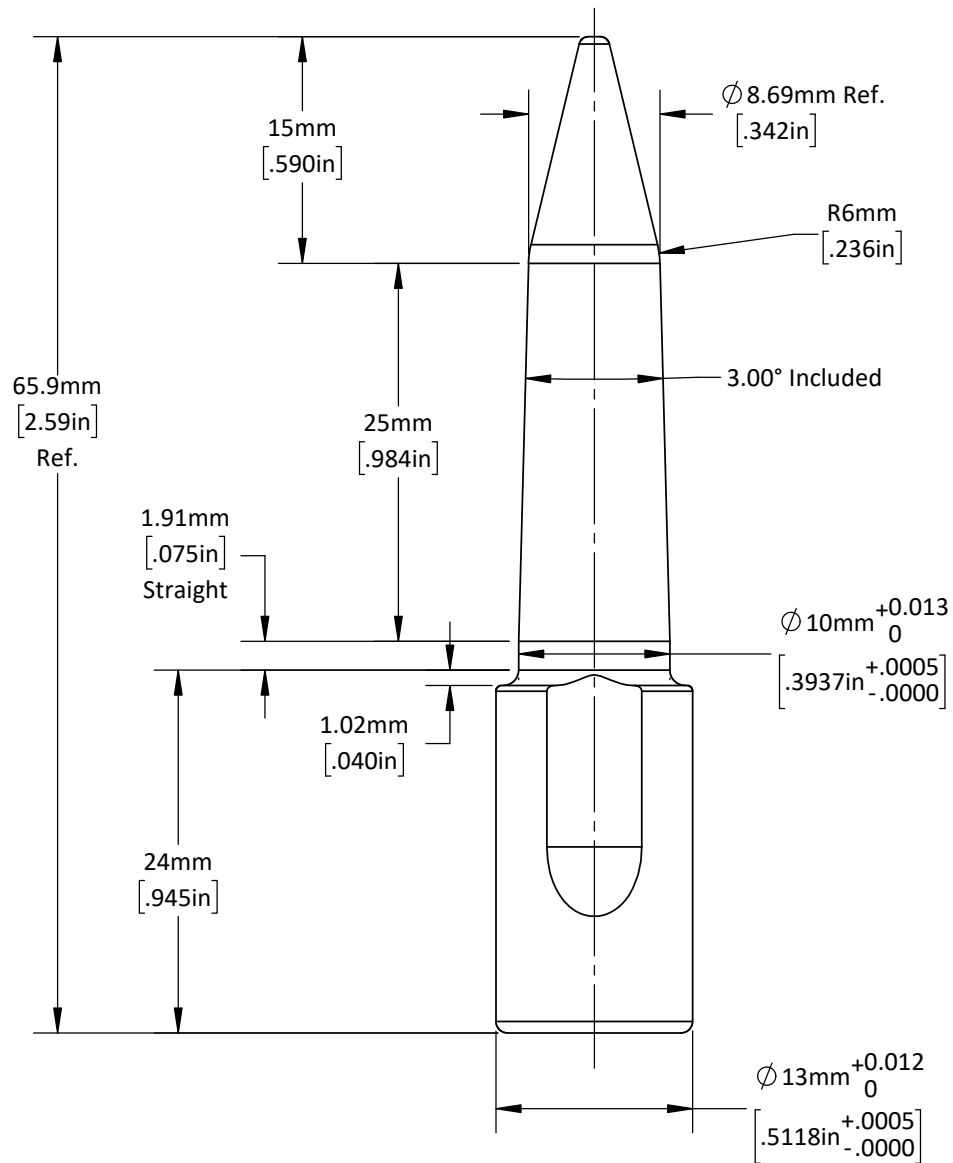

DO NOT SCALE DRAWING

REV 1

Pilot-PA-T-10mm-1.9mm-25mm-3-A-F₁ / F₂

This product may be covered by one or more patents or patent applications.
 See <http://www.standardlifters.com/patents.html> for details.

STANDARD LIFTERS INC