

Ø 6mm Drill Thru
[.236in]

13.10mm
[.516in]

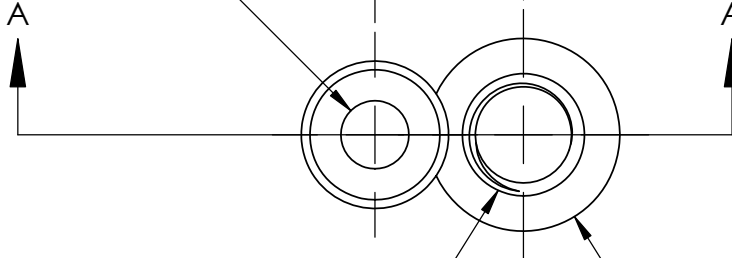

M10-1.5 Tap

Ø 17mm±0.25
[.669in±.010]

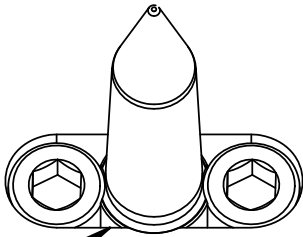

Do Not Slot Fastener Holes
Slotting the Fastener Pocket
Reduces Support to the Pilot Body

Ø 13mm ^{+0.018}₀
[.5118in ^{+0.0007}_{-.0000}]

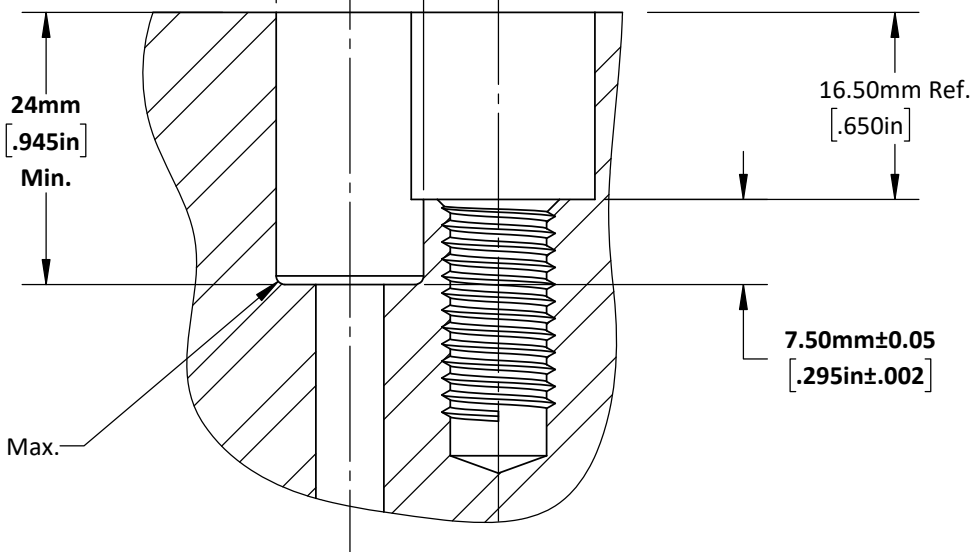

SECTION A-A

DO NOT SCALE DRAWING

REV 1

Pilot-PA-T-10mm-1.9mm-F-Machining

This product may be covered by one or more patents or patent applications.
See <http://www.standardlifters.com/patents.html> for details.

STANDARD LIFTERS INC

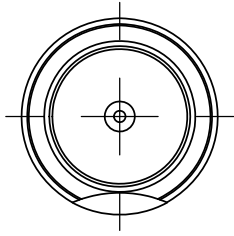

1 Hold Down

PA-T-10mm-1.9mm-13mm-3-A-F1

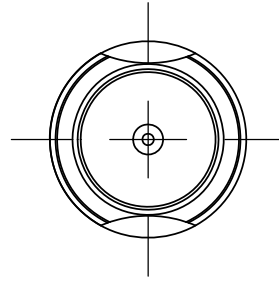

2 Hold Downs

PA-T-10mm-1.9mm-13mm-3-A-F2

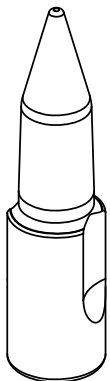
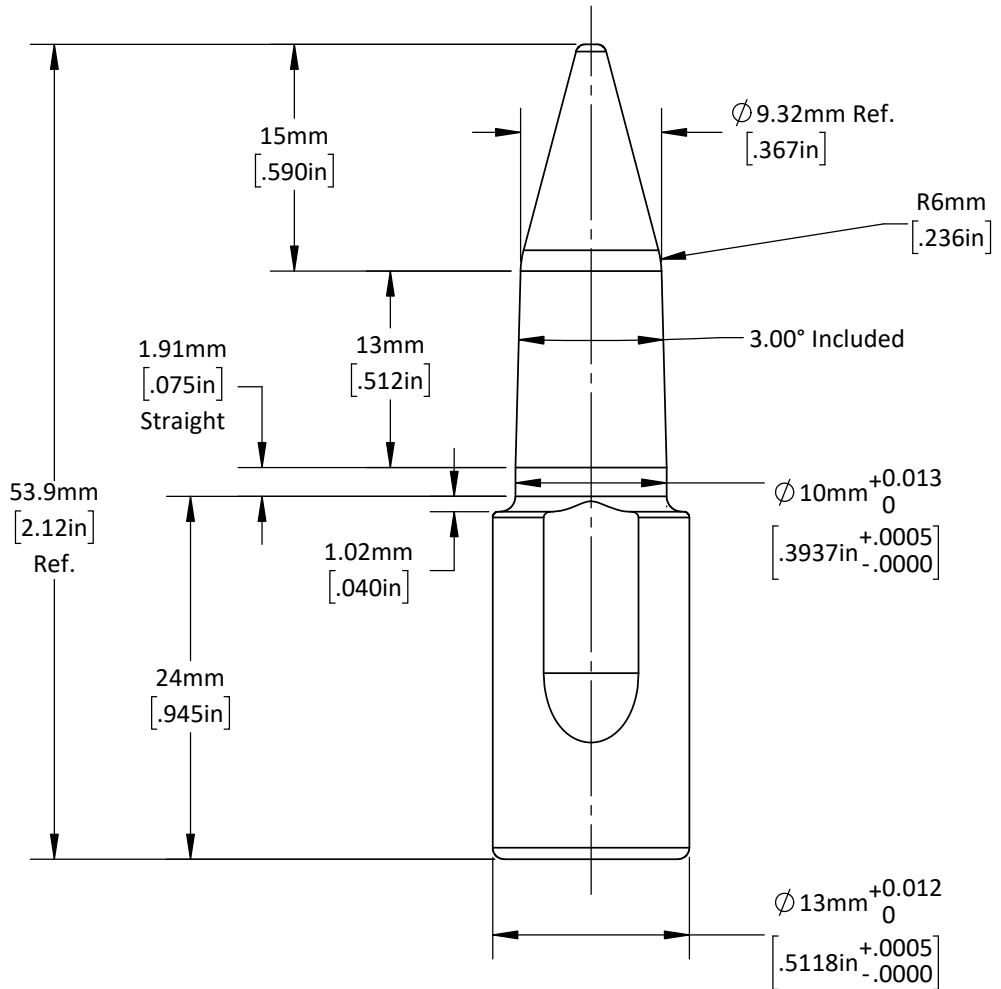

DO NOT SCALE DRAWING

REV 1

Pilot-PA-T-10mm-1.9mm-13mm-3-A-F1 / F2

This product may be covered by one or more patents or patent applications. See <http://www.standardlifters.com/patents.html> for details.

STANDARD LIFTERS INC