

Do Not Slot Fastener Holes
Slotting the Fastener Pocket
Reduces Support to the Pilot Body

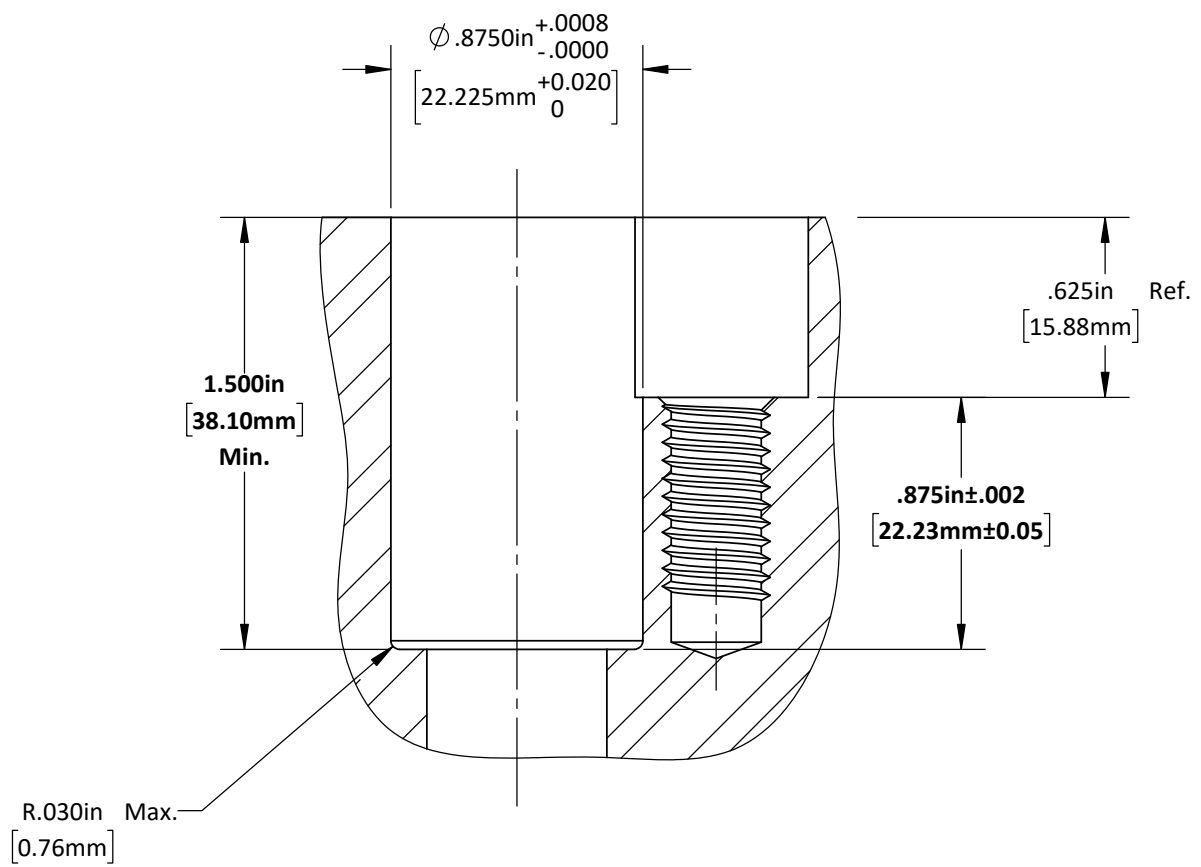

SECTION A-A

DO NOT SCALE DRAWING	REV 1
This product may be covered by one or more patents or patent applications. See http://www.standardlifters.com/patents.html for details.	

Pilot-PA-T-.750-.150-F-Machining
STANDARD LIFTERS INC

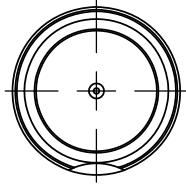

1 Hold Down
PA-T-.750-.150-2.0-3-A-F1

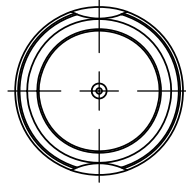

2 Hold Downs
PA-T-.750-.150-2.0-3-A-F2

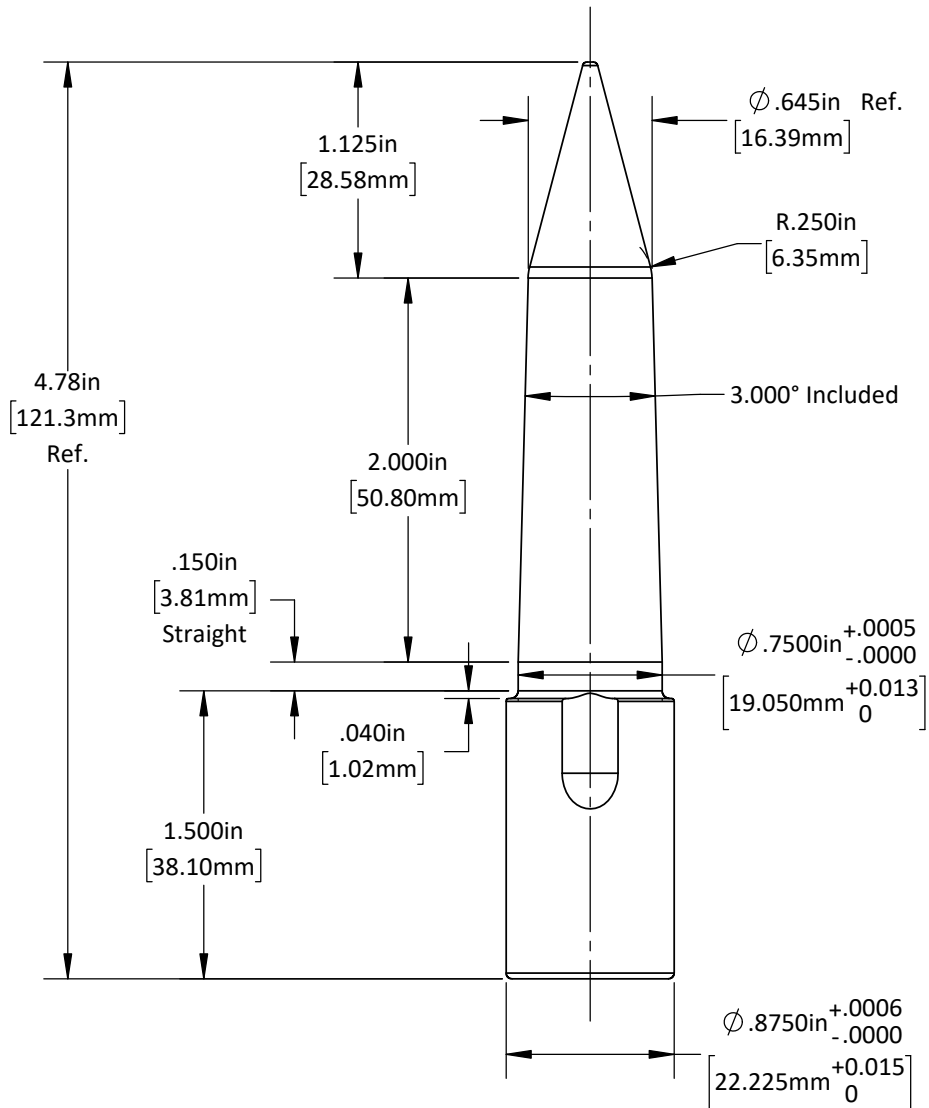
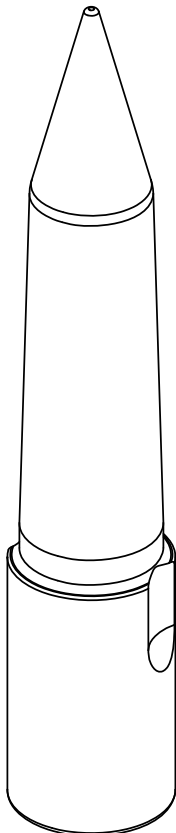

DO NOT SCALE DRAWING

REV 1

Pilot-PA-T-.750-.150-2.0-3-A-F1 / F2

This product may be covered by one or more patents or patent applications.
 See <http://www.standardlifters.com/patents.html> for details.

STANDARD LIFTERS INC