

SECTION A-A

DO NOT SCALE DRAWING

REV 1

This product may be covered by one or more patents or patent applications. See <http://www.standardlifters.com/patents.html> for details.

**Pilot-PA-T-.500-.100-F-Machining**

**STANDARD LIFTERS INC**

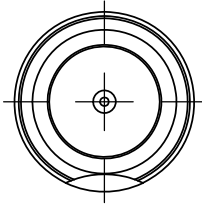

**1 Hold Down**  
**PA-T-.500-.100-2.0-3-A-F1**

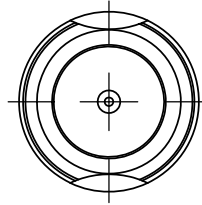

**2 Hold Downs**  
**PA-T-.500-.100-2.0-3-A-F2**

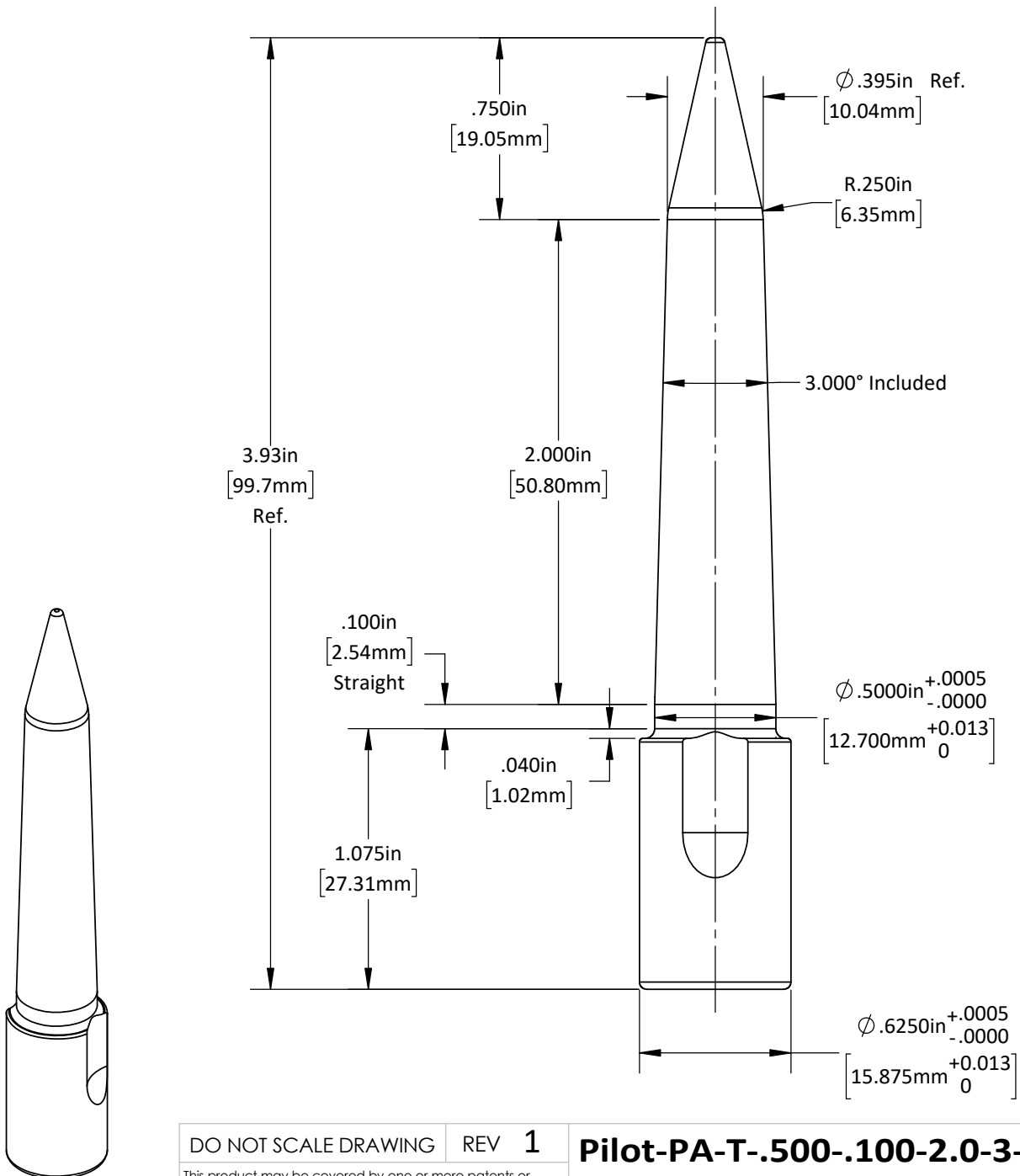

DO NOT SCALE DRAWING    REV 1  
 This product may be covered by one or more patents or patent applications.  
 See <http://www.standardlifters.com/patents.html> for details.

**Pilot-PA-T-.500-.100-2.0-3-A-F1 / F2**  
**STANDARD LIFTERS INC**