

SECTION A-A

DO NOT SCALE DRAWING REV 1

This product may be covered by one or more patents or patent applications.
 See <http://www.standardlifters.com/patents.html> for details.

Pilot-PA-T-.500-.100-F-Machining

STANDARD LIFTERS INC

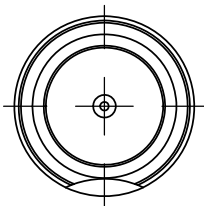

1 Hold Down
PA-T-.500-.100-1.5-3-A-F1

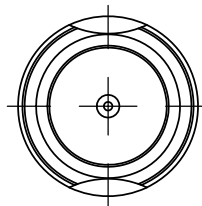

2 Hold Downs
PA-T-.500-.100-1.5-3-A-F2

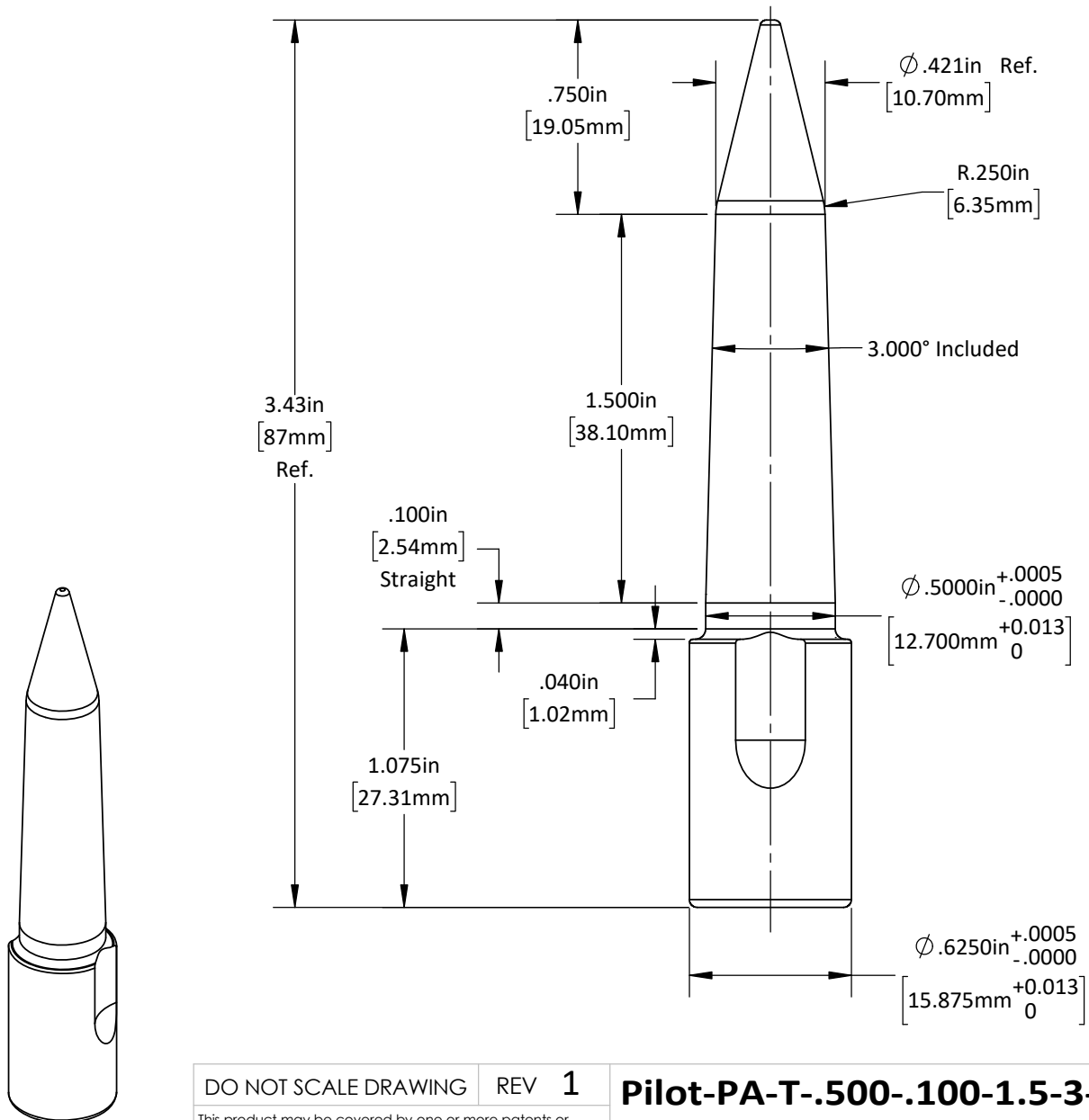

DO NOT SCALE DRAWING REV 1
 This product may be covered by one or more patents or patent applications.
 See <http://www.standardlifters.com/patents.html> for details.

Pilot-PA-T-.500-.100-1.5-3-A-F1 / F2
STANDARD LIFTERS INC