

DO NOT SCALE DRAWING

REV 1

Pilot-PA-8mm-1.27mm-S-P-F-Machining

This product may be covered by one or more patents or patent applications.
See <http://www.standardlifters.com/patents.html> for details.

STANDARD LIFTERS INC

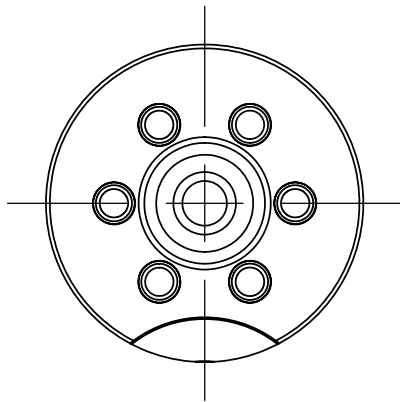

1 Hold Down
PA-8mm-1.27mm-S-P-F1

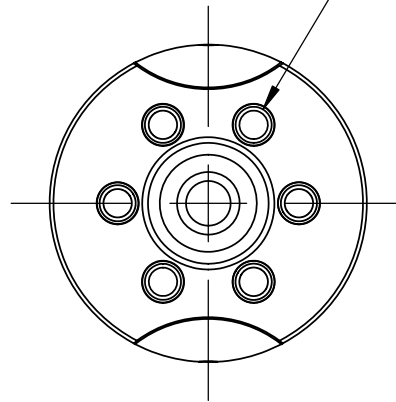

2 Hold Downs
PA-8mm-1.27mm-S-P-F2

Ø 2.4mm [.094in] Ejector Pin
(6) Equally Spaced on a
Ø 12mm [.472in] Bolt Circle

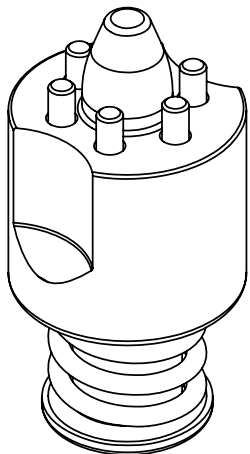
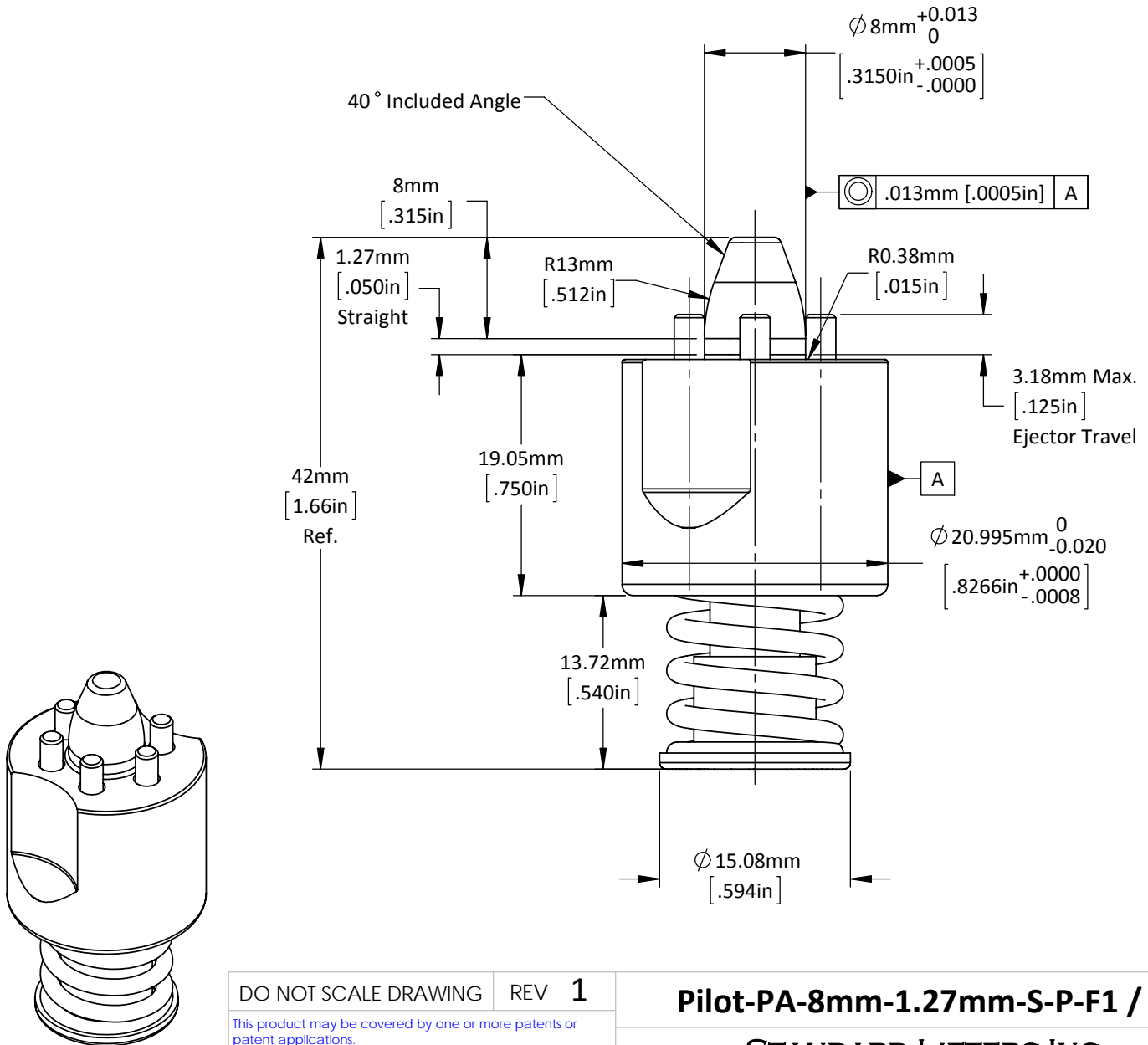

DO NOT SCALE DRAWING REV 1

This product may be covered by one or more patents or patent applications.
See <http://www.standardlifters.com/patents.html> for details.

Pilot-PA-8mm-1.27mm-S-P-F1 / F2

STANDARD LIFTERS INC