

DO NOT SCALE DRAWING

REV 6

This product may be covered by one or more patents or
 patent applications.
 See <http://www.standardlifters.com/patents.html> for details.

Pilot-PA-20mm-3.8mm-S-P-F-Machining

STANDARD LIFTERS INC

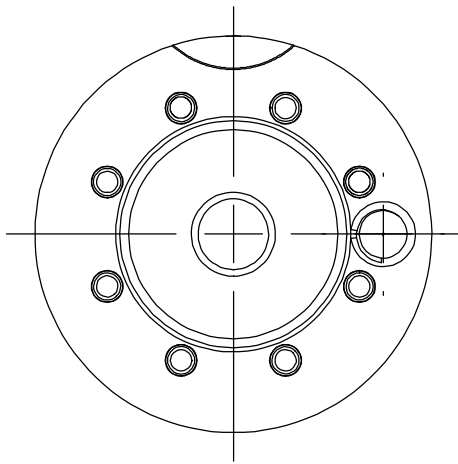

1 Hold Down
PA-20mm-3.8mm-S-P-F1

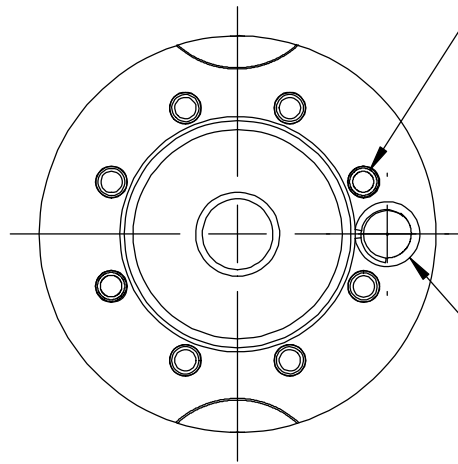

2 Hold Downs
PA-20mm-3.8mm-S-P-F2

Ø 2.4mm [.094in] Ejector Pin
(8) Equally Spaced on a
Ø 24.1mm [.948in] Bolt Circle

M5-0.8 Tap

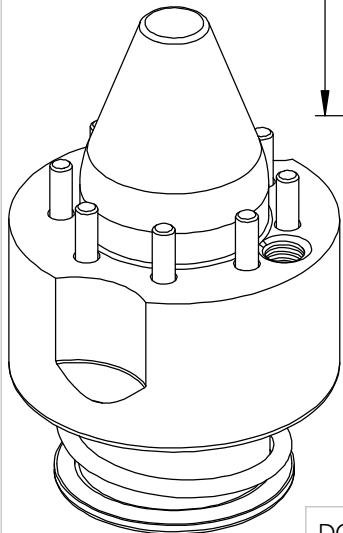
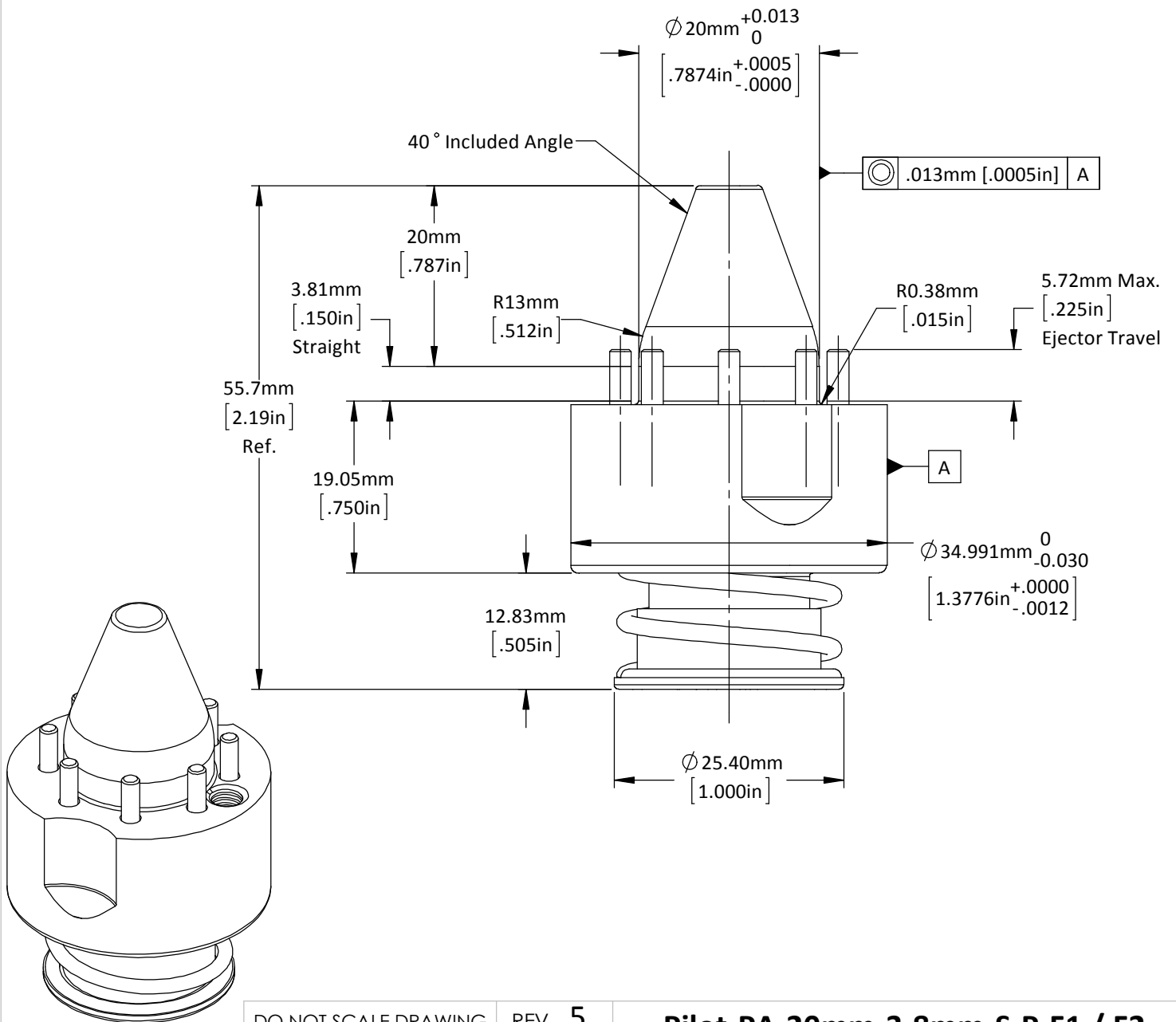

DO NOT SCALE DRAWING REV 5

This product may be covered by one or more patents or patent applications.
See <http://www.standardlifters.com/patents.html> for details.

Pilot-PA-20mm-3.8mm-S-P-F1 / F2

STANDARD LIFTERS INC