

DO NOT SCALE DRAWING

REV 6

**Pilot-PA-16mm-3.2mm-S-P-F-Machining**

This product may be covered by one or more patents or patent applications. See <http://www.standardlifters.com/patents.html> for details.

STANDARD LIFTERS INC

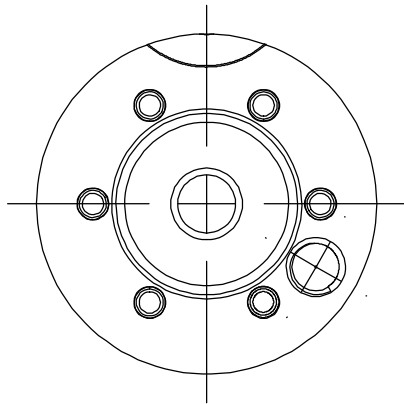

**1 Hold Down**  
**PA-16mm-3.2mm-S-P-F1**

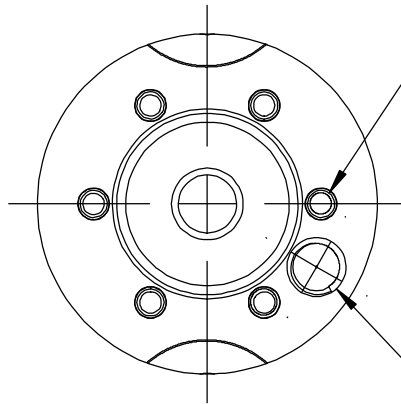

Ø 2.4mm [.094in] Ejector Pin  
 (6) Equally Spaced on a  
 Ø 20mm [.790in] Bolt Circle

M5-0.8 Tap

**2 Hold Downs**  
**PA-16mm-3.2mm-S-P-F2**

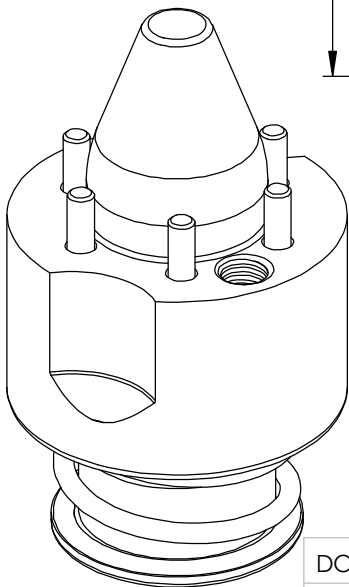
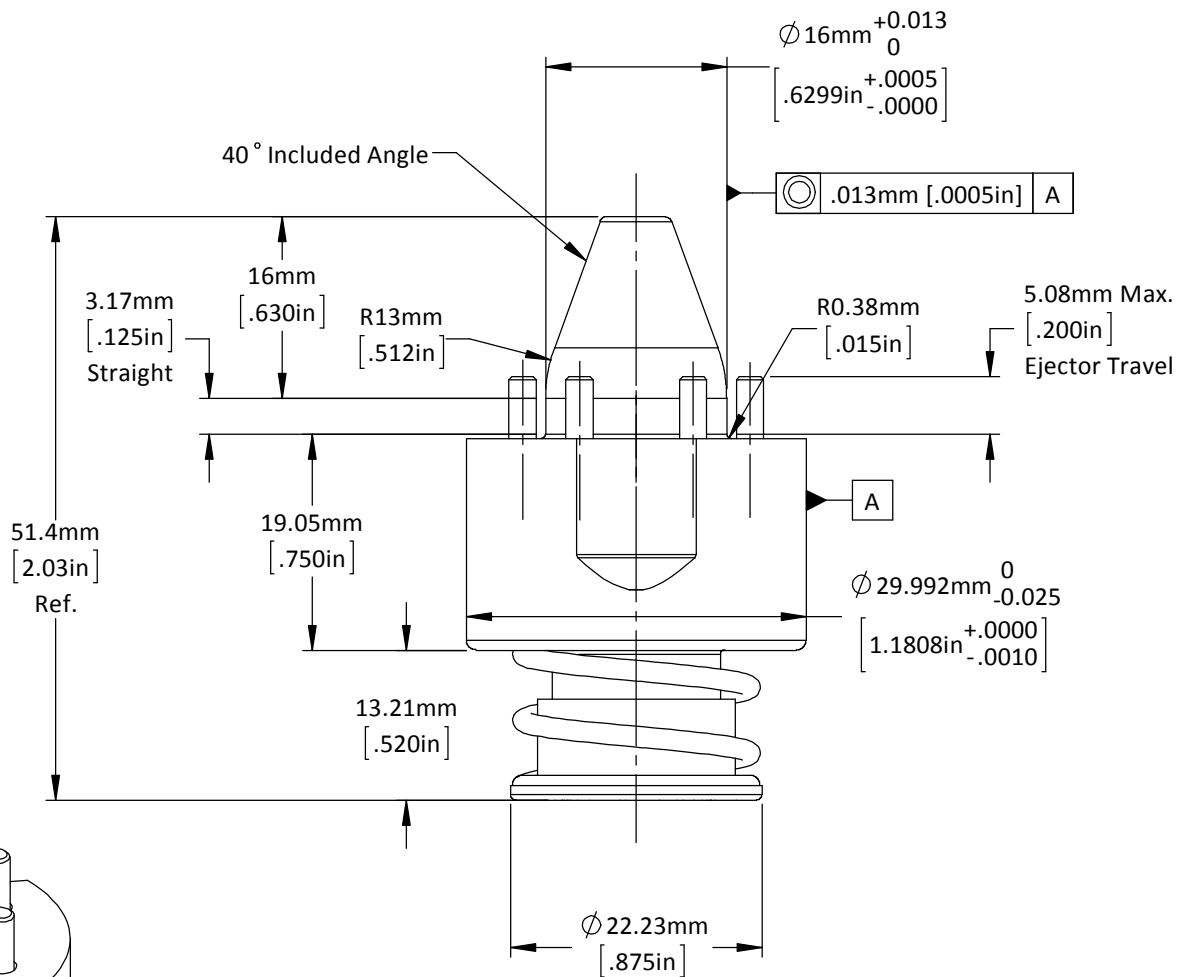

DO NOT SCALE DRAWING

REV 5

This product may be covered by one or more patents or patent applications. See <http://www.standardlifters.com/patents.html> for details.

**Pilot-PA-16mm-3.2mm-S-P-F1 / F2**

STANDARD LIFTERS INC