

DO NOT SCALE DRAWING

REV 6

This product may be covered by one or more patents or  
 patent applications.  
 See <http://www.standardlifters.com/patents.html> for details.

**Pilot-PA-13mm-2.5mm-L-P-F-Machining**

STANDARD LIFTERS INC

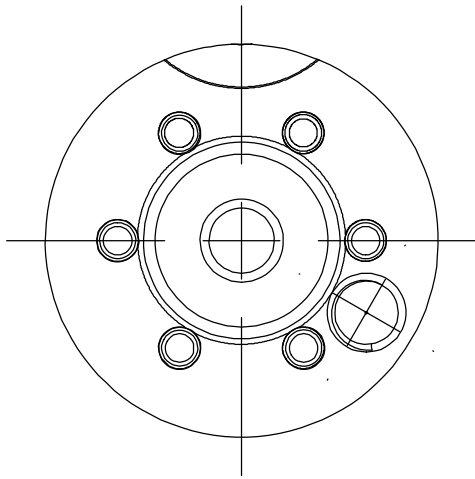

**1 Hold Down**  
**PA-13mm-2.5mm-L-P-F1**

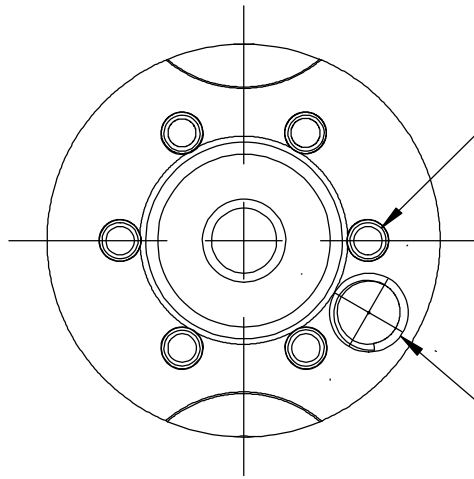

**2 Hold Downs**  
**PA-13mm-2.5mm-L-P-F2**

Ø 2.4mm [.094in] Ejector Pin  
(6) Equally Spaced on a  
Ø 16.41mm [.646in] Bolt Circle

M5-0.8mm Tap

