

DO NOT SCALE DRAWING

REV 6

This product may be covered by one or more patents or patent applications.  
See <http://www.standardlifters.com/patents.html> for details.

**Pilot-PA-10mm-1.9mm-S-P-F-Machining**

STANDARD LIFTERS INC

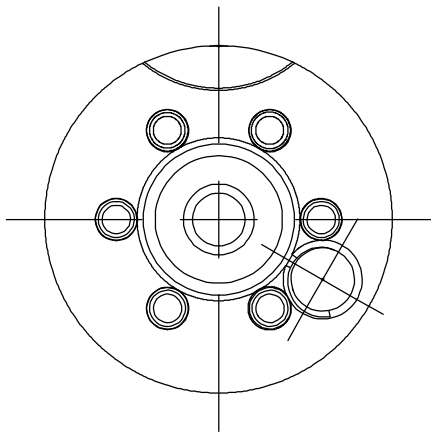

**1 Hold Down**  
**PA-10mm-1.9mm-S-P-F1**

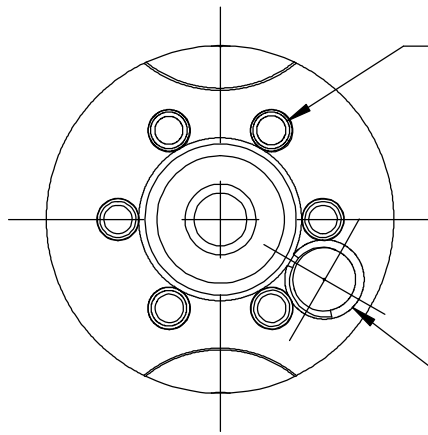

**2 Hold Downs**  
**PA-10mm-1.9mm-S-P-F2**

Ø 2.4mm [.094in] Ejector Pin  
(6) Equally Spaced on a  
Ø 13.56mm [.534in] Bolt Circle

M5-0.8 Tap

