

DO NOT SCALE DRAWING

REV 6

Pilot-PA-10mm-1.9mm-L-P-F-Machining

This product may be covered by one or more patents or patent applications.
 See <http://www.standardlifters.com/patents.html> for details.

STANDARD LIFTERS INC

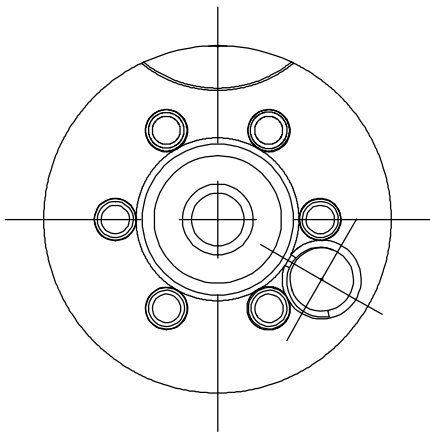

1 Hold Down
PA-10mm-1.9mm-L-P-F1

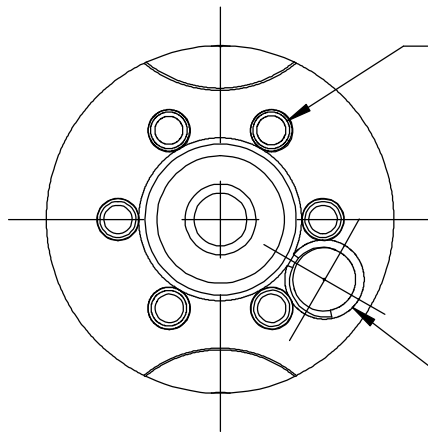

2 Hold Downs
PA-10mm-1.9mm-L-P-F2

Ø 2.4mm [.094in] Ejector Pin
(6) Equally Spaced on a
Ø 13.56mm [.534in] Bolt Circle

M5-0.8 Tap

