

SECTION B-B

DO NOT SCALE DRAWING

REV 3

This product may be covered by one or more patents or patent applications. See <http://www.standardlifters.com/patents.html> for details.

Pilot-PA-.750-.150-L-P-W-Machining

STANDARD LIFTERS INC

\varnothing .094in [2.4mm] Ejector Pin
 (8) Equally Spaced on a
 \varnothing .910in [23.11mm] Bolt Circle

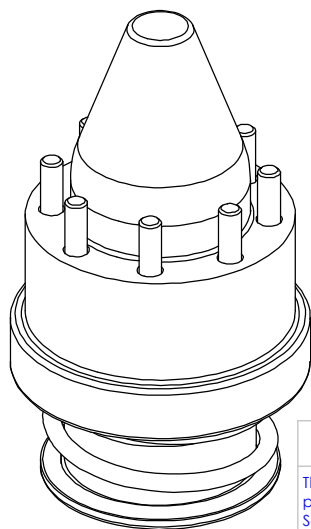
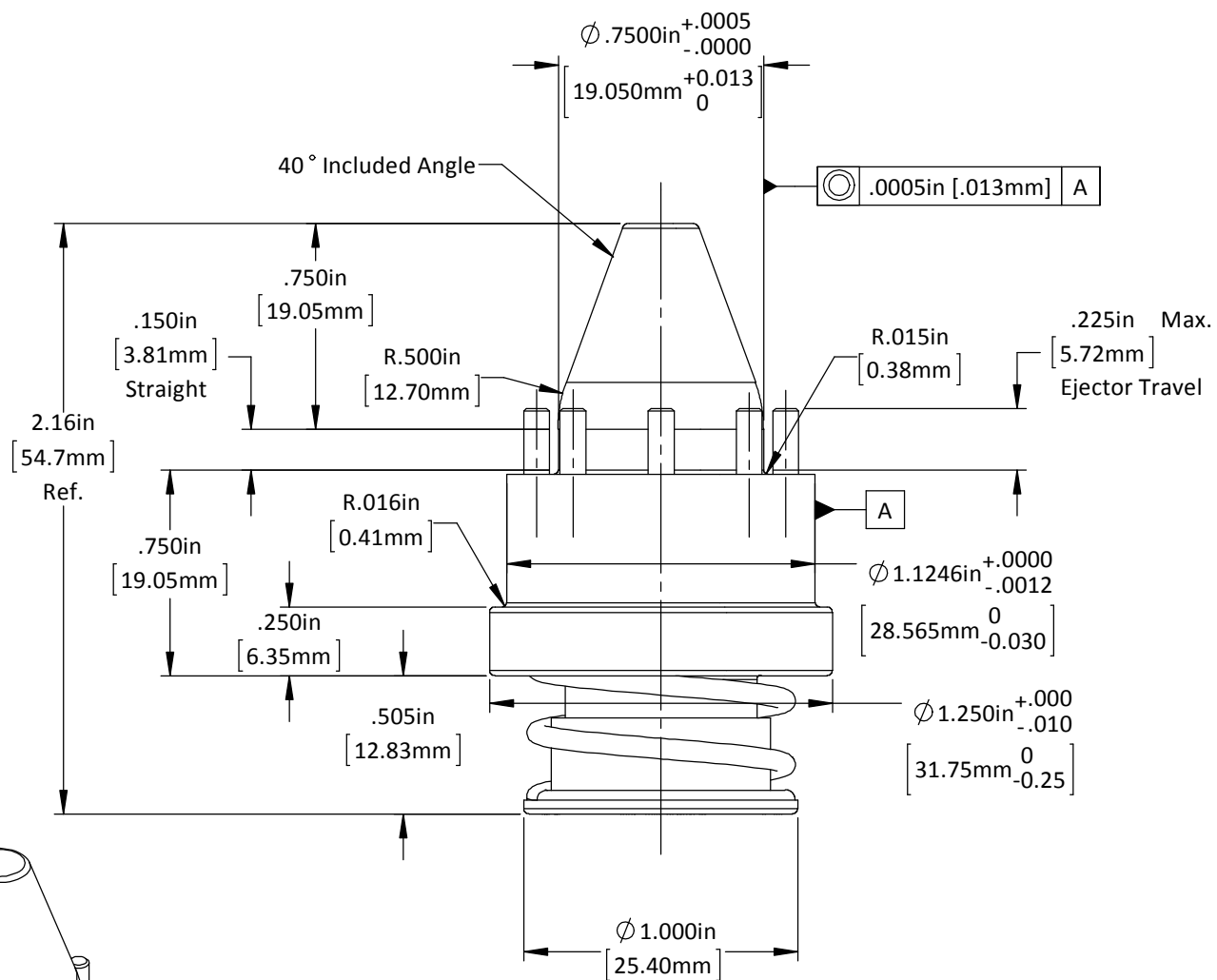
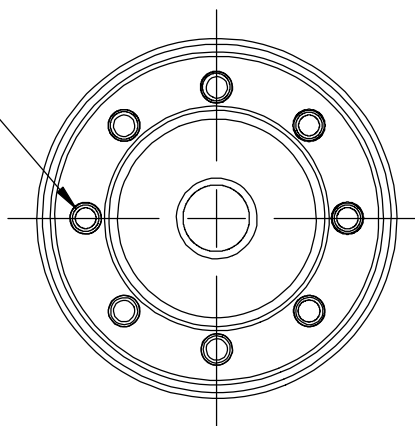

DO NOT SCALE DRAWING REV 2

This product may be covered by one or more patents or patent applications.
 See <http://www.standardlifters.com/patents.html> for details.

Pilot-PA-.750-.150-L-P-W

STANDARD LIFTERS INC