

DO NOT SCALE DRAWING

REV 6

This product may be covered by one or more patents or  
 patent applications.  
 See <http://www.standardlifters.com/patents.html> for details.

**Pilot-PA-.625-.125-S-P-F-Machining**

STANDARD LIFTERS INC

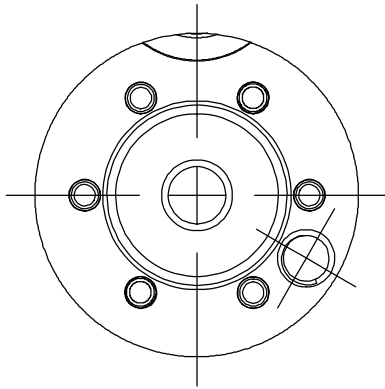

**1 Hold Down**  
**PA-.625-.125-S-P-F1**

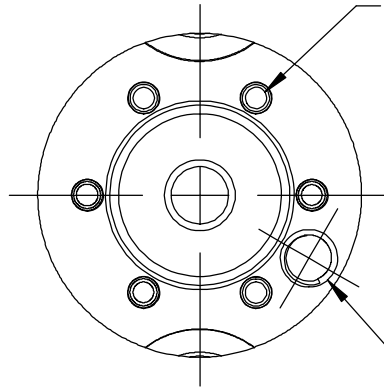

**2 Hold Downs**  
**PA-.625-.125-S-P-F2**

Ø .094in [2.4mm] Ejector Pin  
(6) Equally Spaced on a  
Ø .780in [19.81mm] Bolt Circle

#10-32 Tap

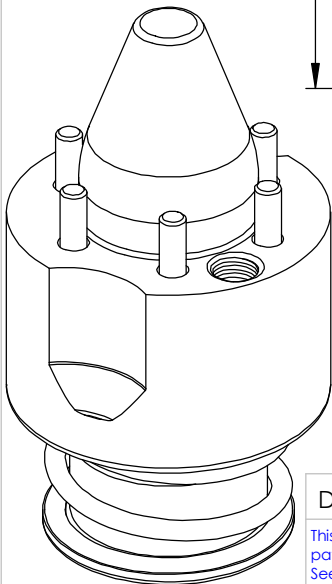
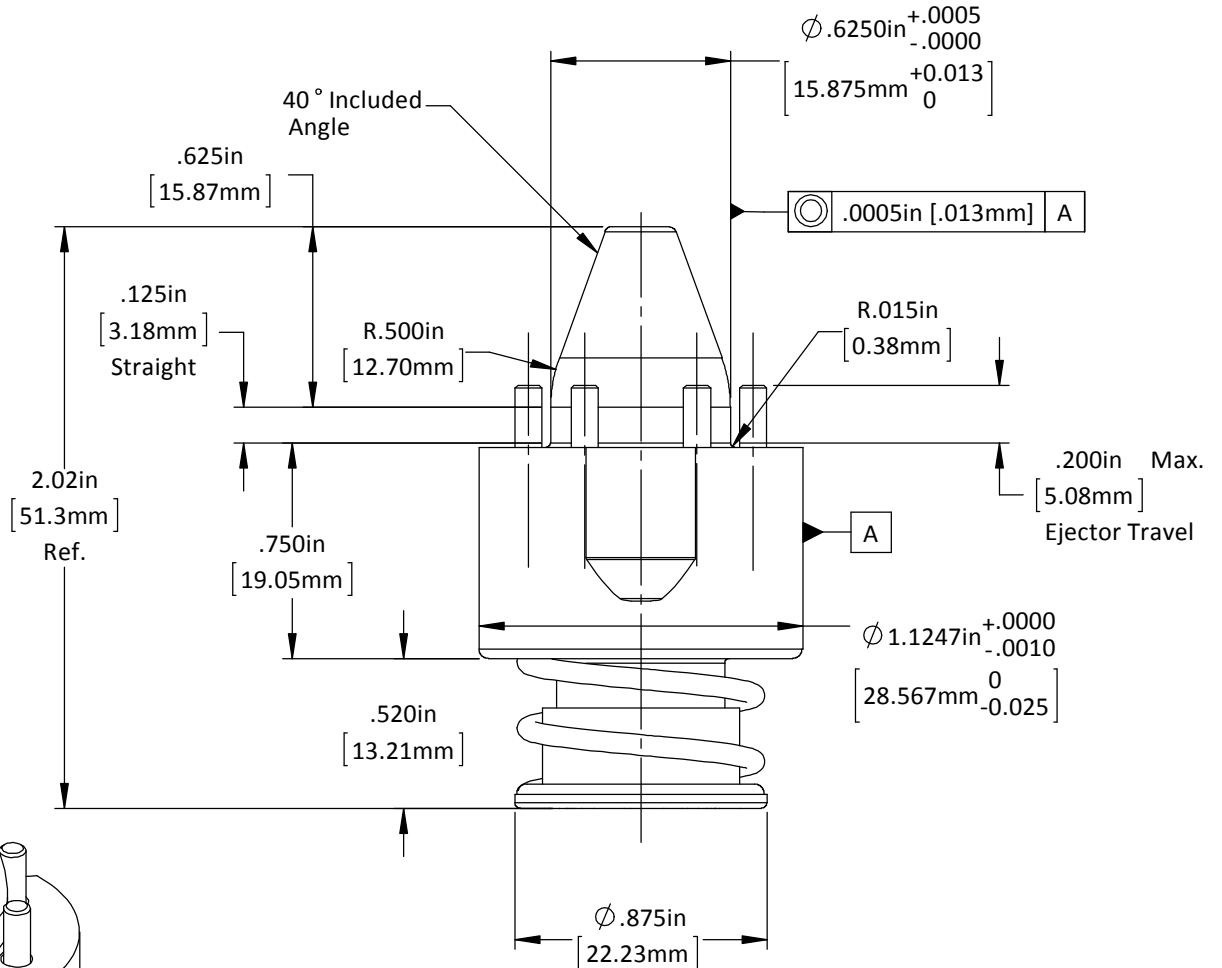

DO NOT SCALE DRAWING REV 5

This product may be covered by one or more patents or patent applications.  
See <http://www.standardlifters.com/patents.html> for details.

**Pilot-PA-.625-.125-S-P-F1 / F2**

STANDARD LIFTERS INC