

DO NOT SCALE DRAWING

REV 6

This product may be covered by one or more patents or  
 patent applications.  
 See <http://www.standardlifters.com/patents.html> for details.

**Pilot-PA-.500-.100-S-P-F-Machining**

STANDARD LIFTERS INC

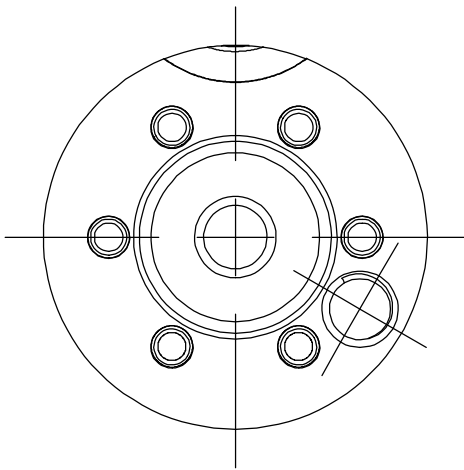

**1 Hold Down**  
**PA-.500-.100-S-P-F1**

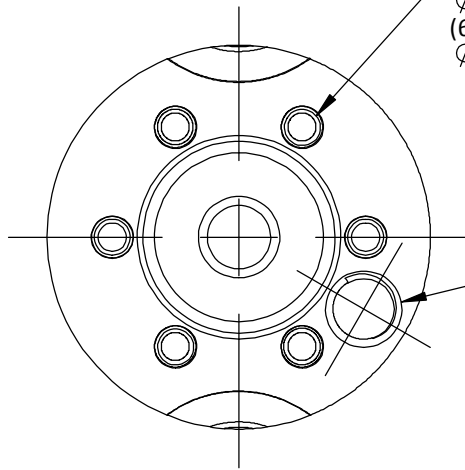

**2 Hold Downs**  
**PA-.500-.100-S-P-F2**

$\phi$ .094in [2.4mm] Ejector Pin  
 (6) Equally Spaced on a  
 $\phi$ .660in [16.76mm] Bolt Circle

#10-32 Tap

