

DO NOT SCALE DRAWING

REV 6

This product may be covered by one or more patents or patent applications.
 See <http://www.standardlifters.com/patents.html> for details.

Pilot-PA-.375-.075-S-P-F-Machining

STANDARD LIFTERS INC

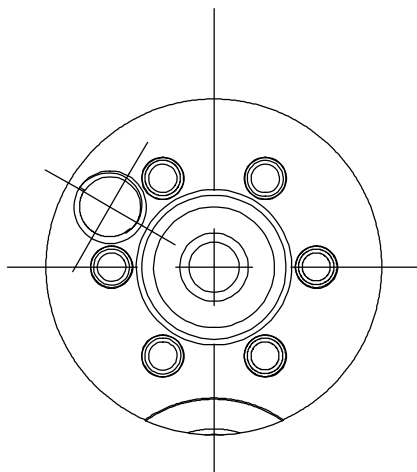

1 Hold Down
PA-.375-.075-S-P-F1

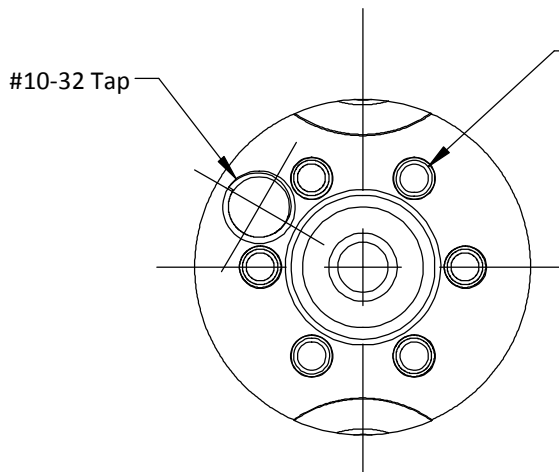

2 Hold Downs
PA-.375-.075-S-P-F2

Ø .094in [2.4mm] Ejector Pin
(6) Equally Spaced on a
Ø .534in [13.56mm] Bolt Circle

#10-32 Tap

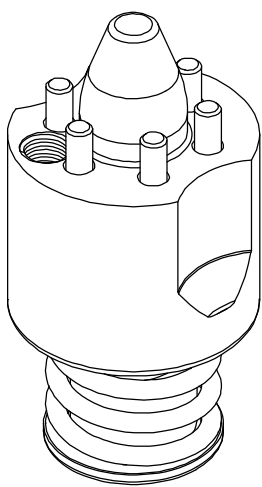
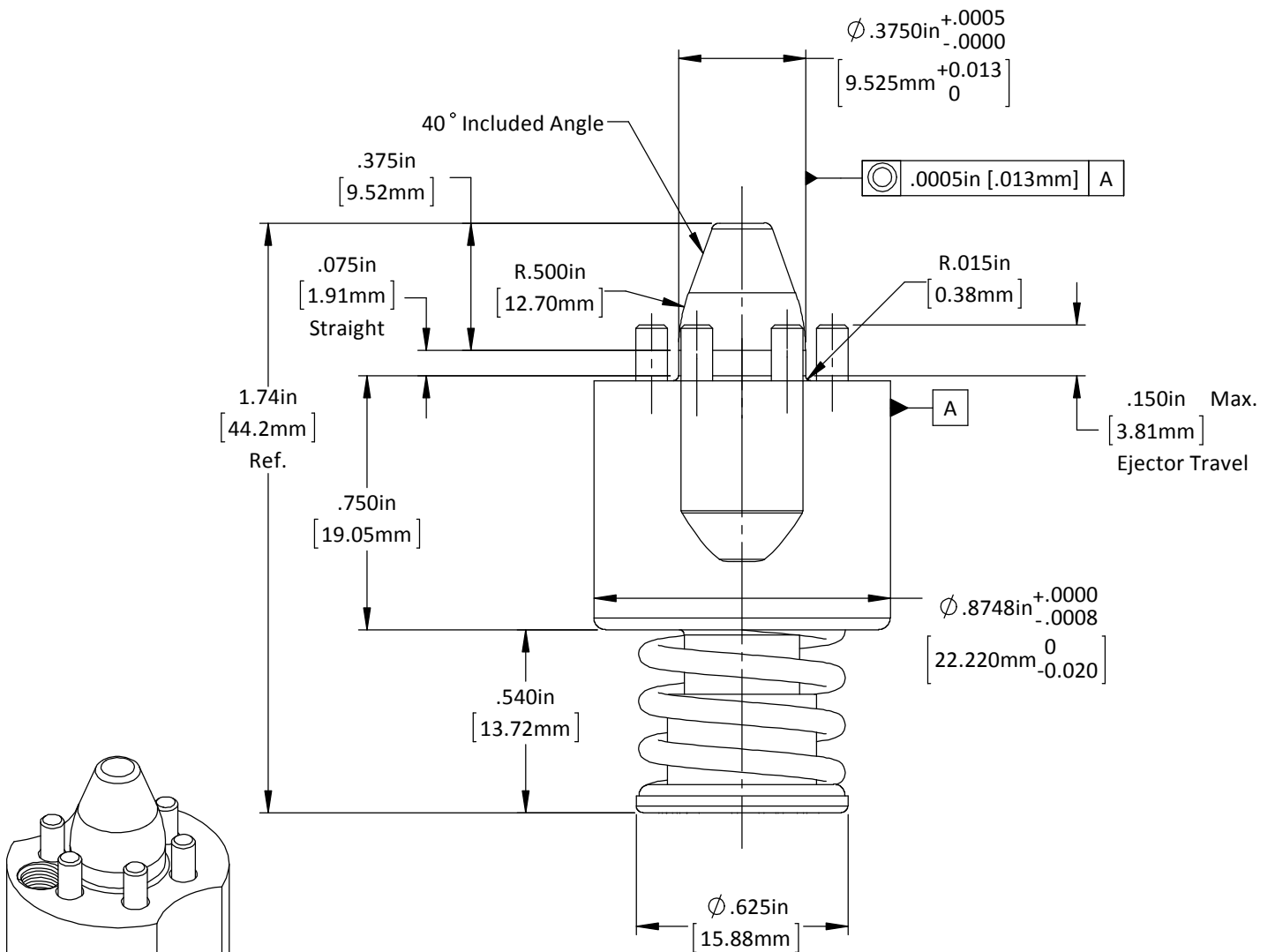

DO NOT SCALE DRAWING REV 5

This product may be covered by one or more patents or patent applications.
See <http://www.standardlifters.com/patents.html> for details.

Pilot-PA-.375-.075-S-P-F1 / F2

STANDARD LIFTERS INC