

"E" = 3/8"-16 Tap X .75in Dp.
"M" = M10-1.50 Tap X 20mm Dp.

*Recommended Minimum Hole Size to be
Cylinder Body Diameter +1mm [.04"]

DO NOT SCALE DRAWING

REV 1

This product may be covered by one or more patents or
patent applications.
See <http://www.standardlifters.com/patents.html> for details.

Gas Spring Clamp-GSC-50-B-Machining

STANDARD LIFTERS INC

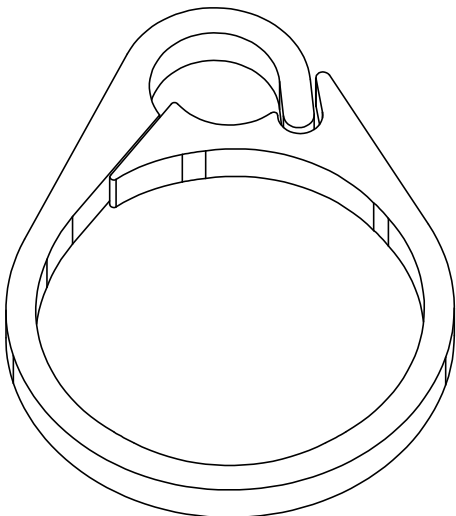
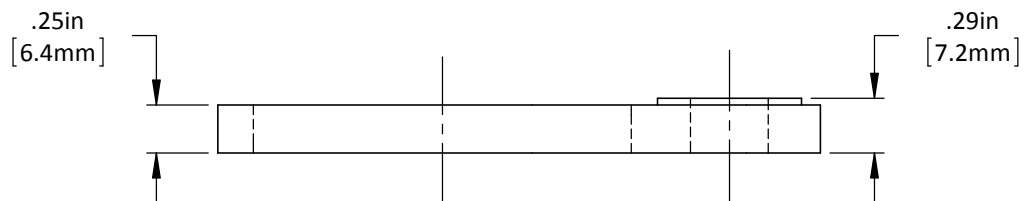
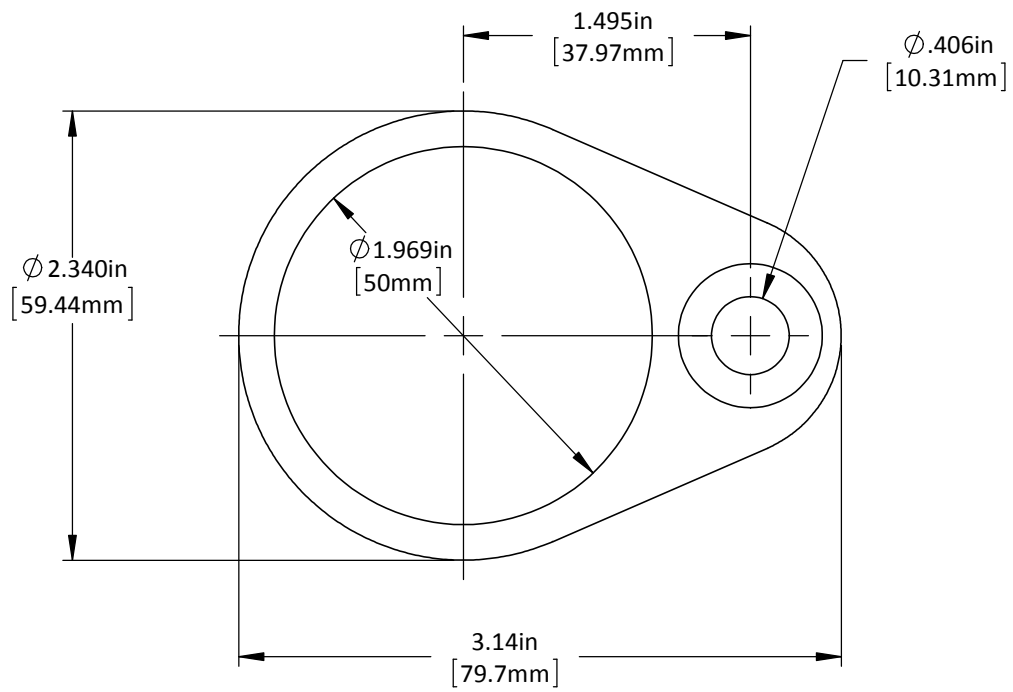

DO NOT SCALE DRAWING

REV 1

This product may be covered by one or more patents or patent applications. See <http://www.standardlifters.com/patents.html> for details.

Gas Spring Clamp-GSC-50-B

STANDARD LIFTERS INC