

\*Recommended Minimum Hole Size to be  
Cylinder Body Diameter +1mm [.04"]

DO NOT SCALE DRAWING

REV 1

**Gas Spring Clamp-GSC-44.5-A-Machining**

This product may be covered by one or more patents or  
patent applications.  
See <http://www.standardlifters.com/patents.html> for details.

**STANDARD LIFTERS INC**

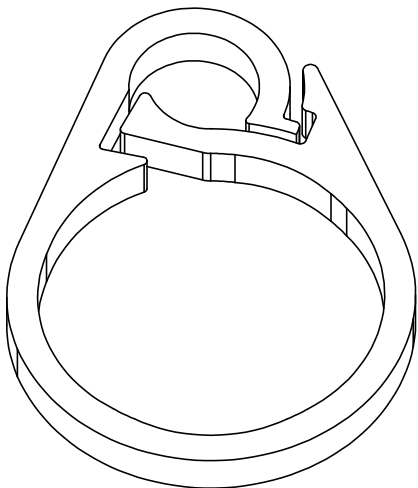
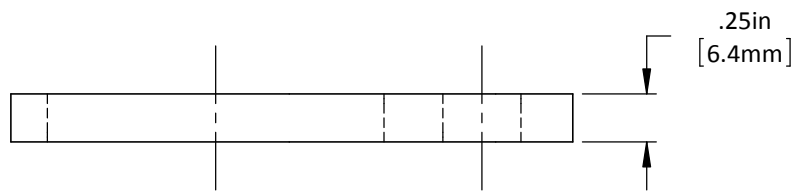
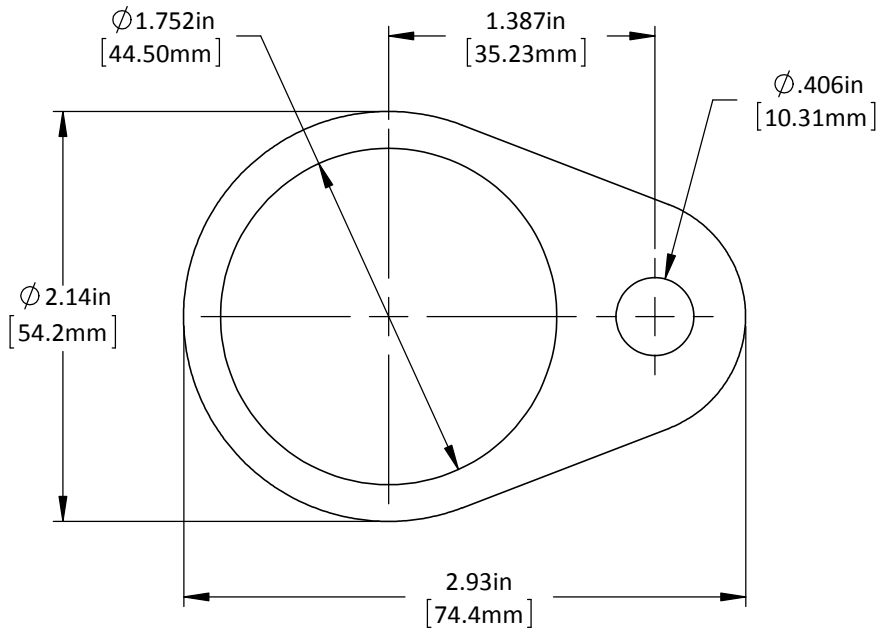

DO NOT SCALE DRAWING    REV 1

This product may be covered by one or more patents or patent applications.  
See <http://www.standardlifters.com/patents.html> for details.

**Gas Spring Clamp-GSC-44.5-A**

**STANDARD LIFTERS INC**