

\*Recommended Minimum Hole Size to be  
Cylinder Body Diameter +1mm [.04"]

"E" = 3/8"-16 Tap X .75in Dp.  
"M" = M10-1.50 Tap X 20mm Dp.

DO NOT SCALE DRAWING	REV 1	<b>Gas Spring Clamp-GSC-32-A-Machining</b>
This product may be covered by one or more patents or patent applications. See <a href="http://www.standardlifters.com/patents.html">http://www.standardlifters.com/patents.html</a> for details.		

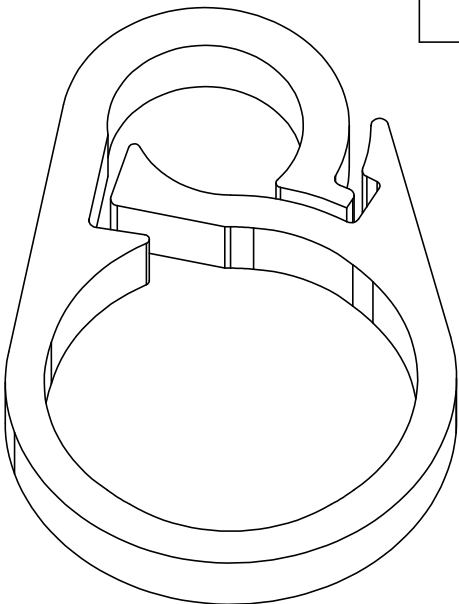
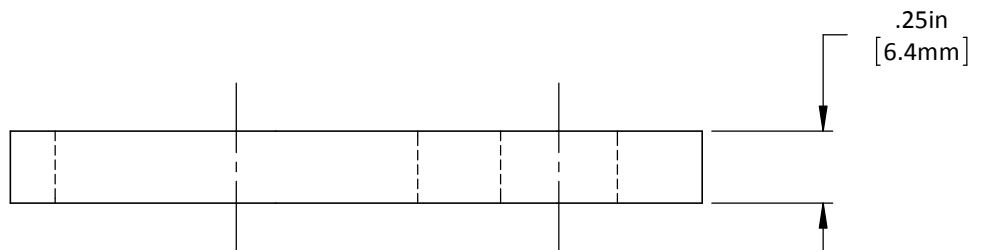
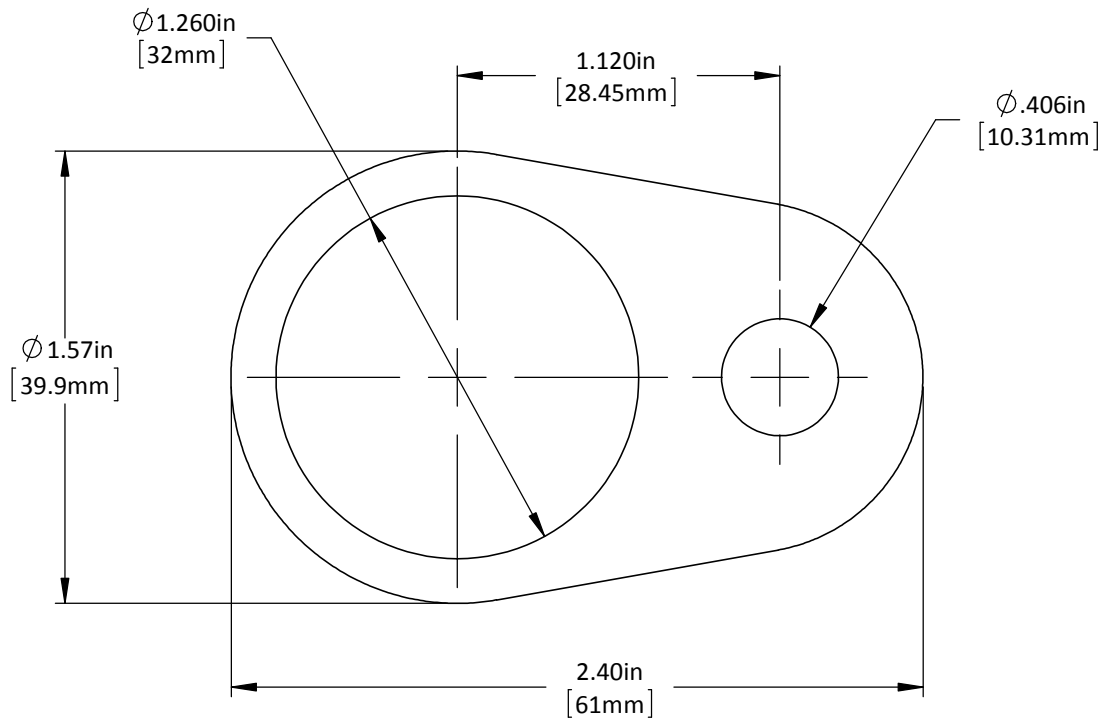

DO NOT SCALE DRAWING | REV 1

This product may be covered by one or more patents or patent applications.  
 See <http://www.standardlifters.com/patents.html> for details.

**Gas Spring Clamp-GSC-32-A**

**STANDARD LIFTERS INC**