

*Recommended Minimum Hole Size to be
Cylinder Body Diameter +1mm [.04"]

"E" = 5/16"-18 Tap X .62in Dp.
"M" = M8-1.25 Tap X 16mm Dp.

DO NOT SCALE DRAWING

REV 1

This product may be covered by one or more patents or
patent applications.
See <http://www.standardlifters.com/patents.html> for details.

Gas Spring Clamp-GSC-25-A-Machining

STANDARD LIFTERS INC

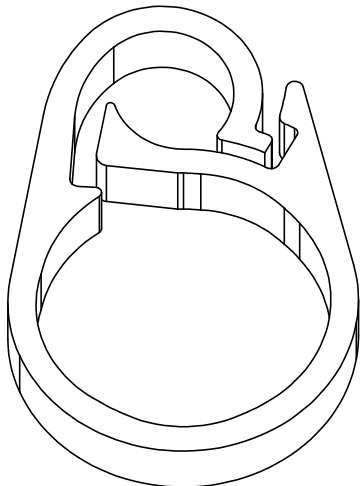
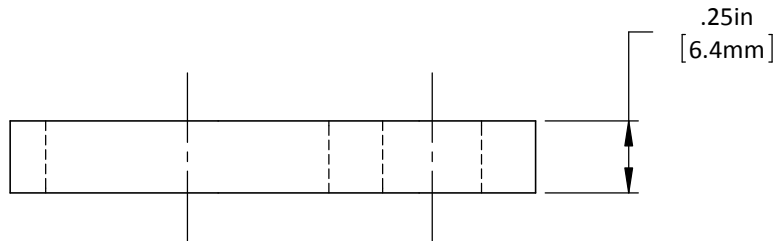
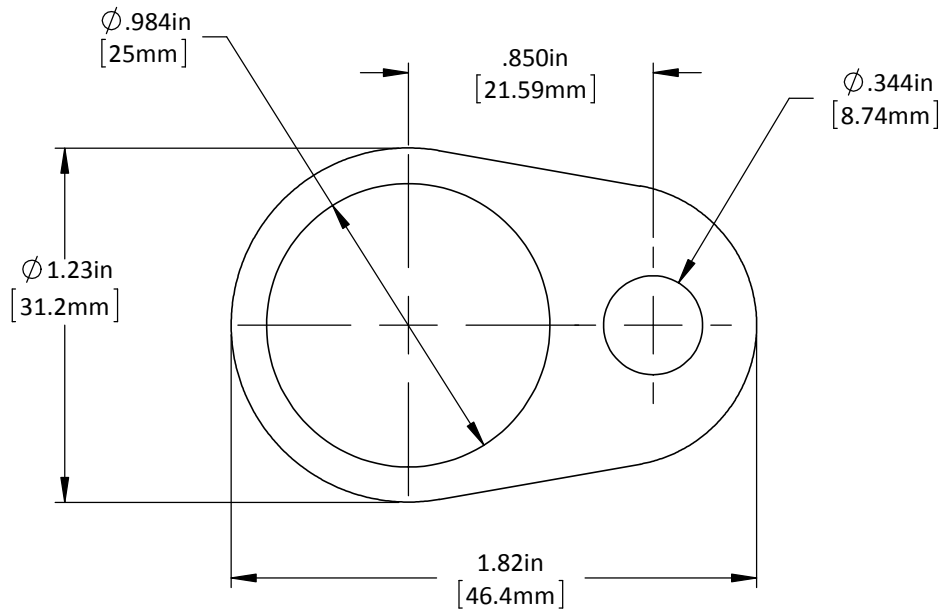

DO NOT SCALE DRAWING | REV 1
 This product may be covered by one or more patents or patent applications.
 See <http://www.standardlifters.com/patents.html> for details.

Gas Spring Clamp-GSC-25-A
STANDARD LIFTERS INC