

DO NOT SCALE DRAWING

REV 2

This product may be covered by one or more patents or patent applications.
 See <http://www.standardlifters.com/patents.html> for details.

SE-.750-.125-S-A-T

STANDARD LIFTERS INC

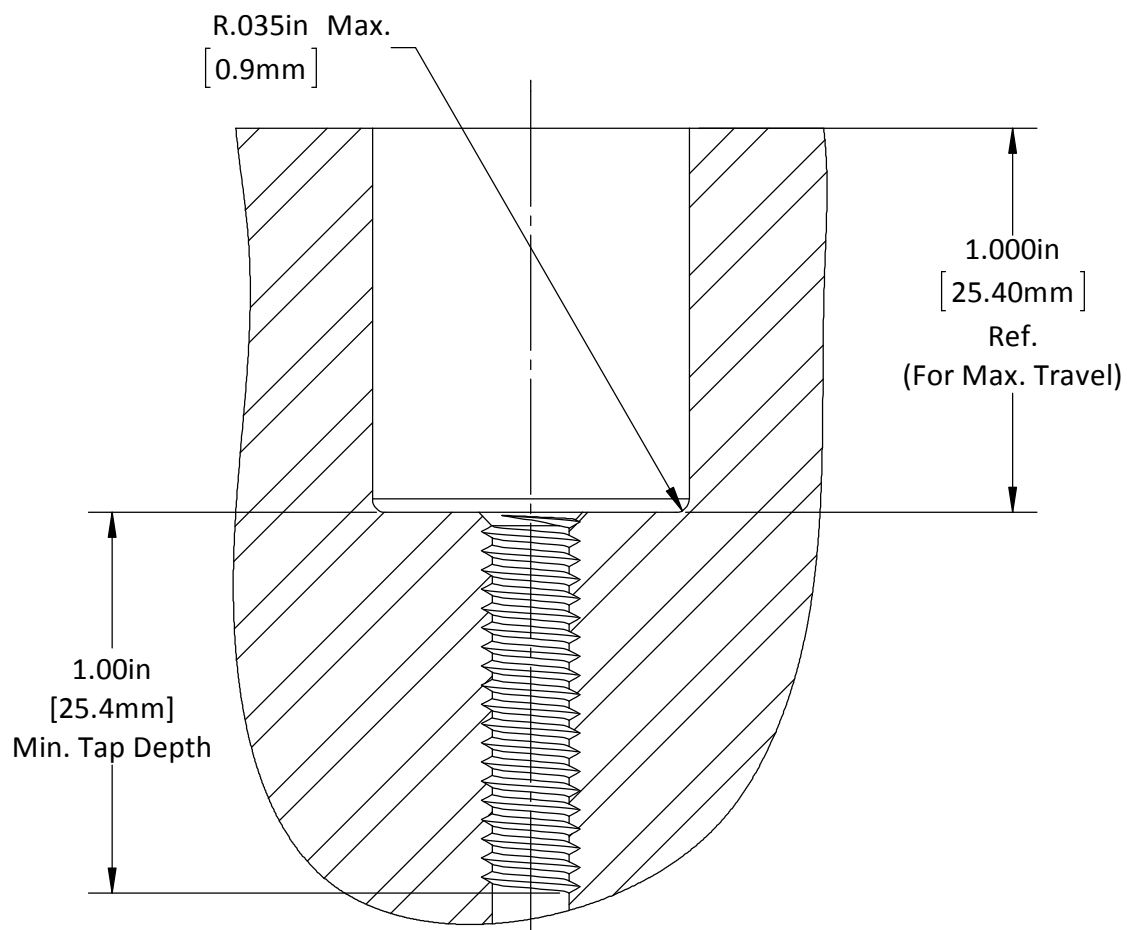
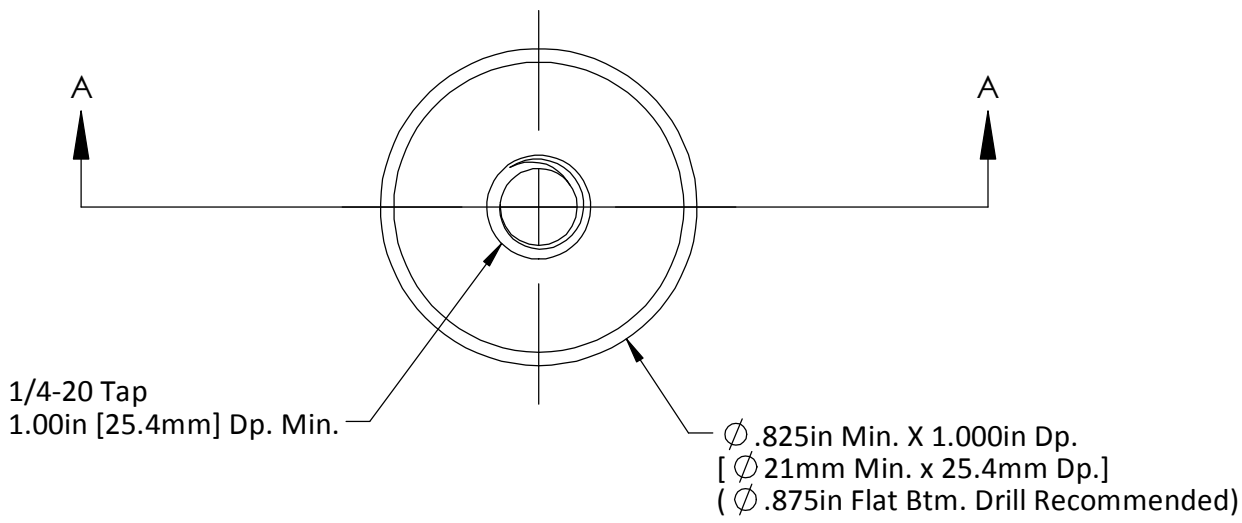

SECTION A-A

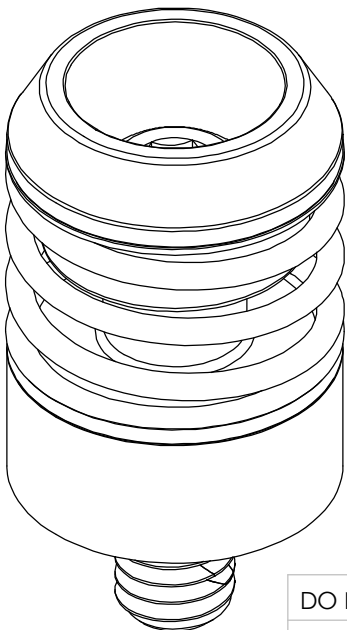
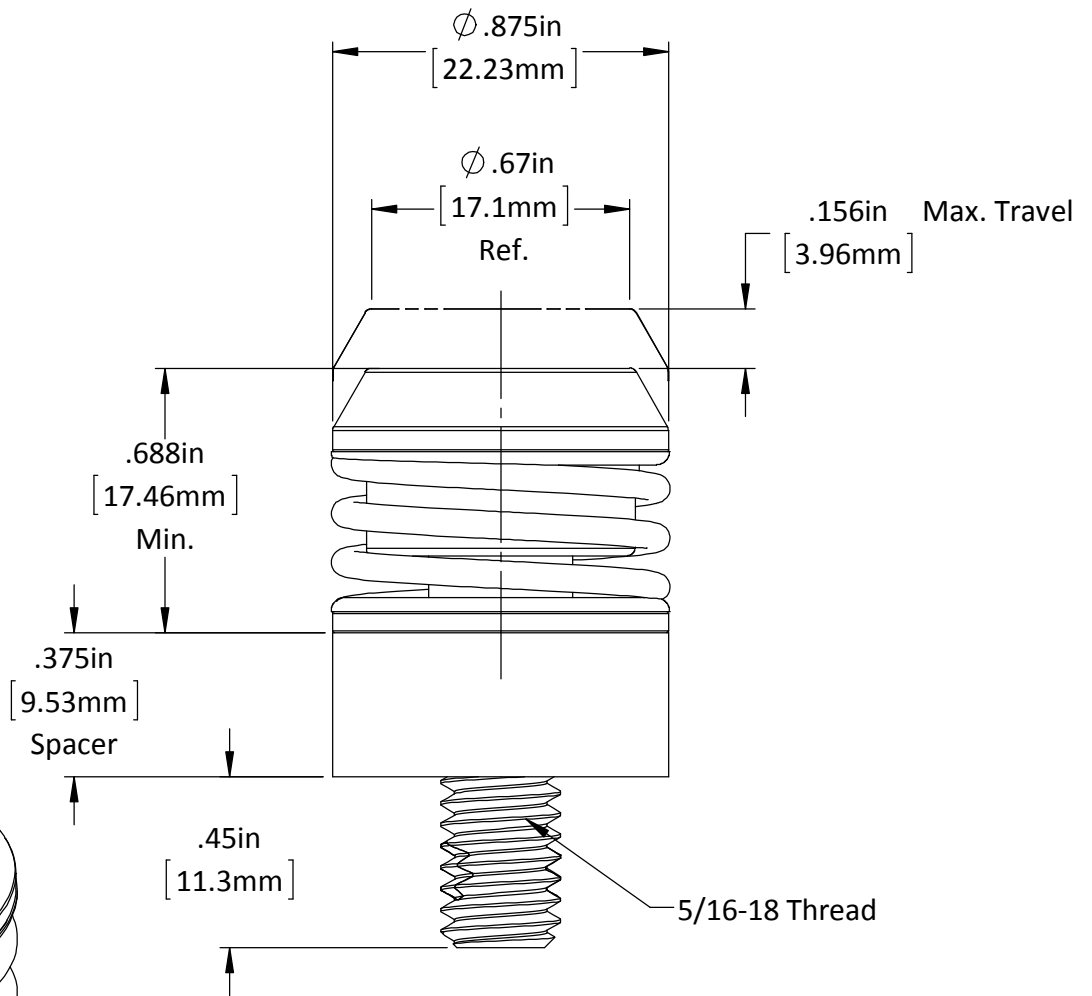
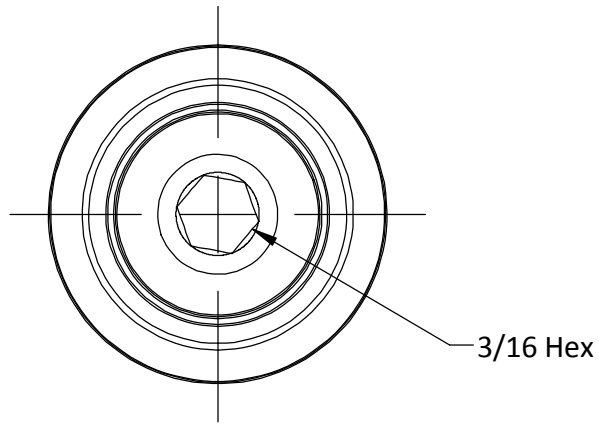

DO NOT SCALE DRAWING REV 2

This product may be covered by one or more patents or patent applications. See <http://www.standardlifters.com/patents.html> for details.

SE-.875-.156-S-A-T

STANDARD LIFTERS INC

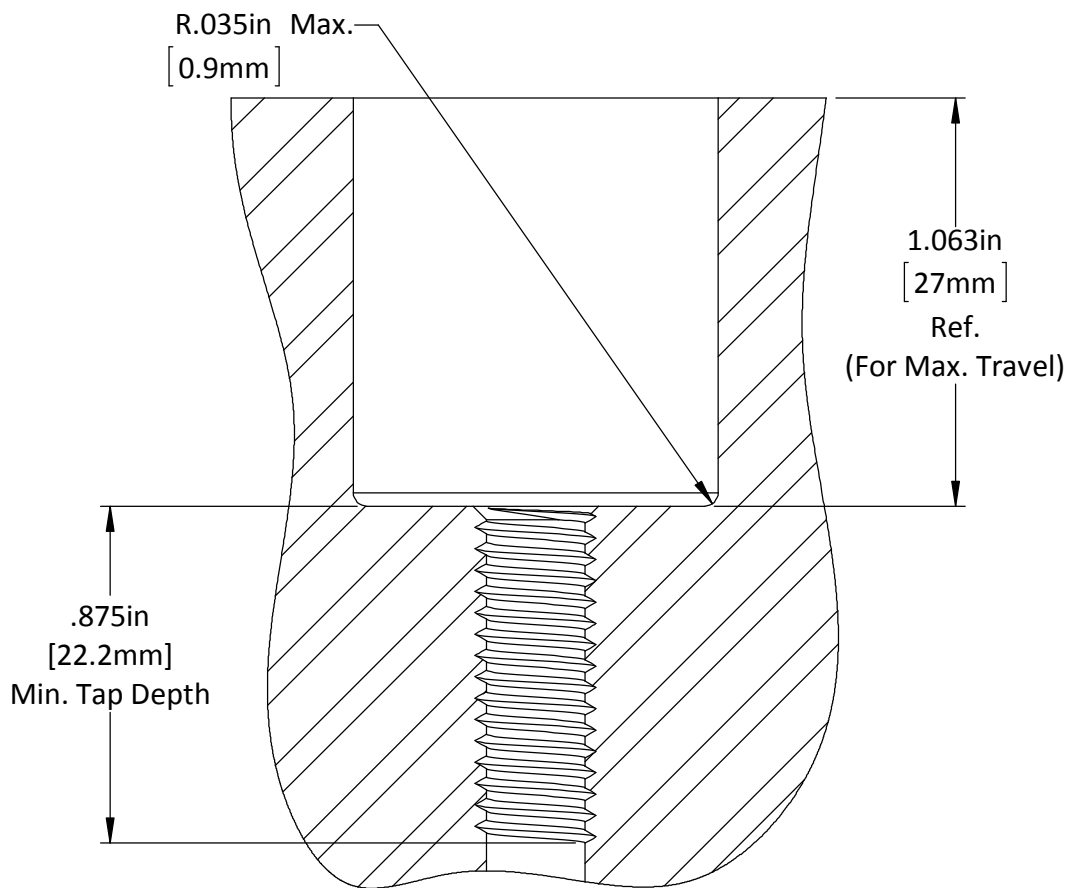
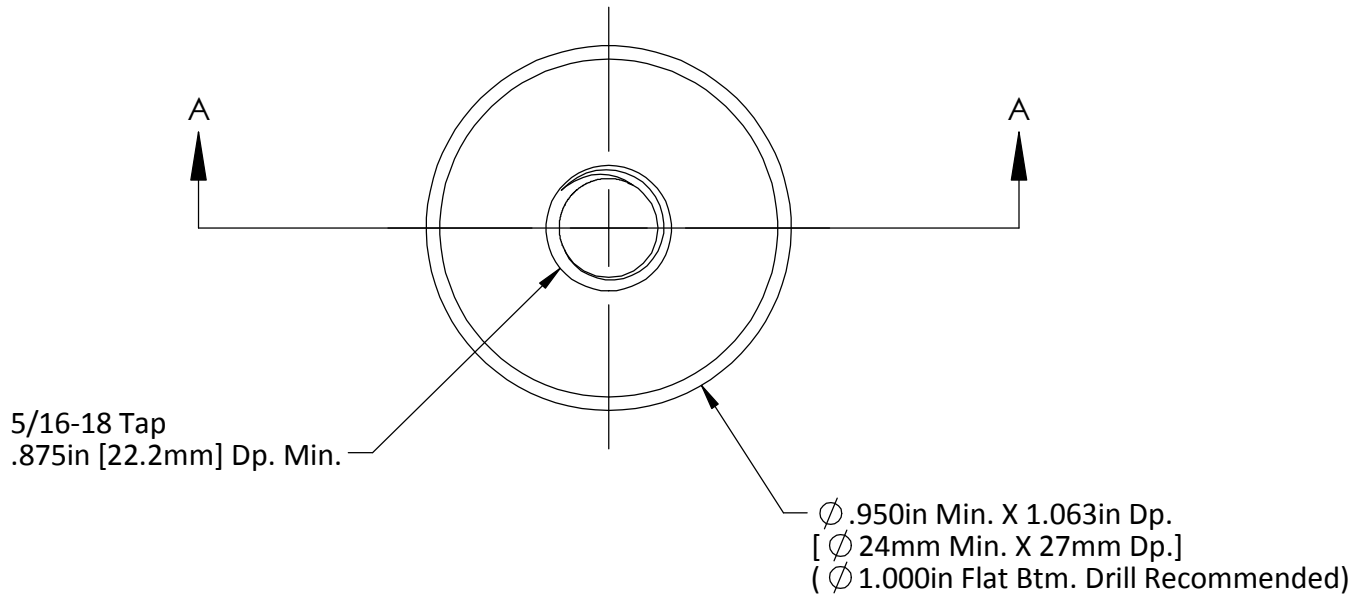

SECTION A-A

DO NOT SCALE DRAWING

REV 2

This product may be covered by one or more patents or patent applications.
See <http://www.standardlifters.com/patents.html> for details.

SE-.875-.156-S-A-T-Machining

STANDARD LIFTERS INC

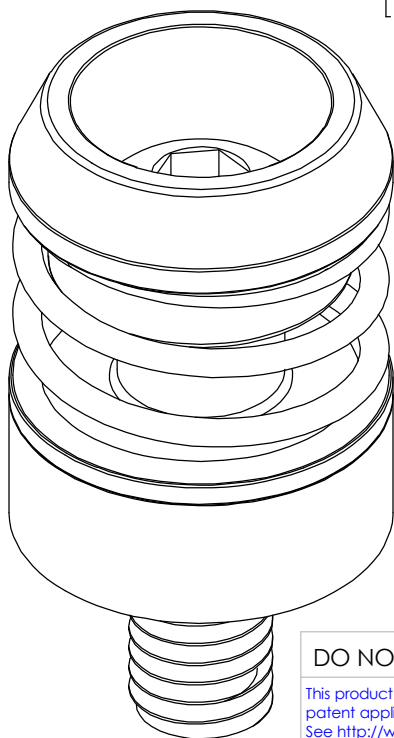
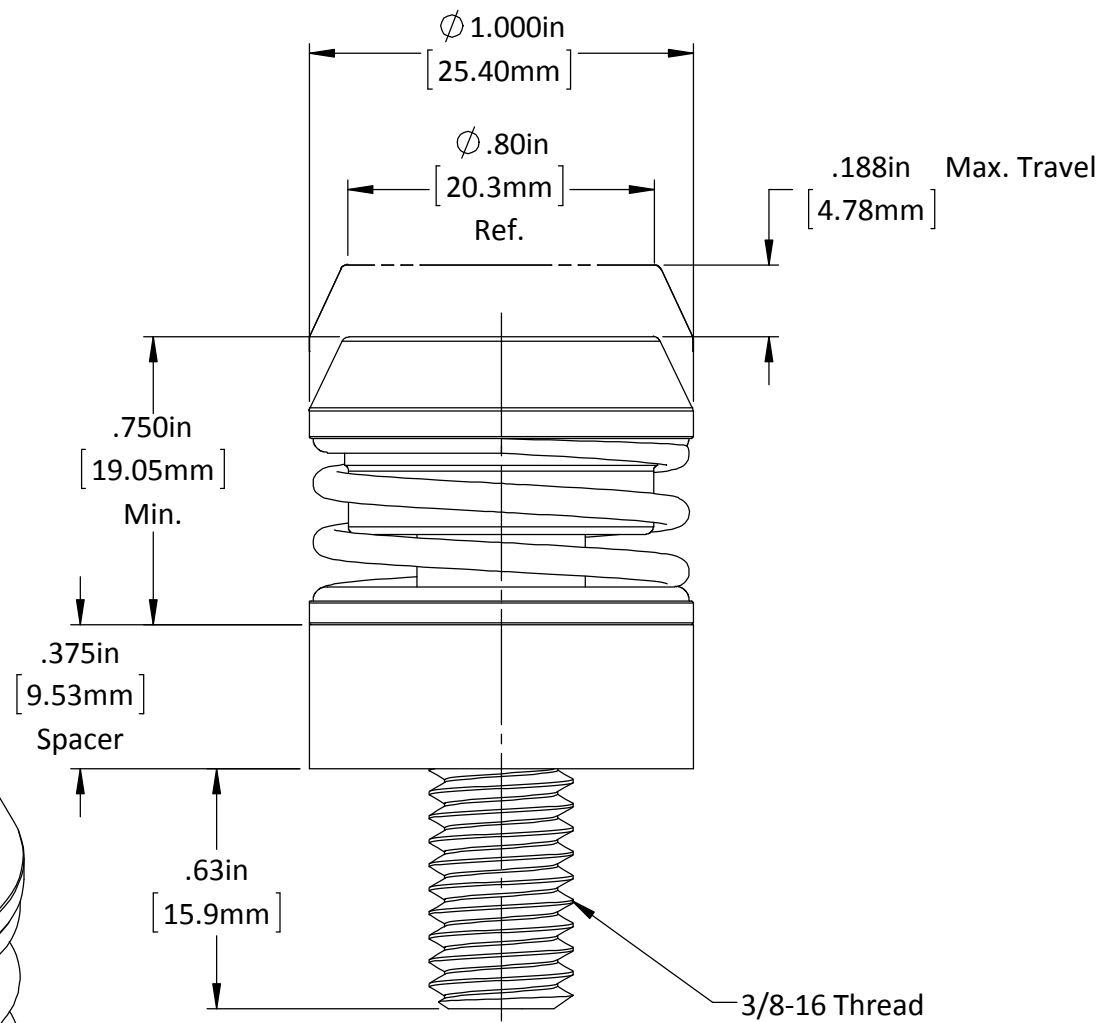
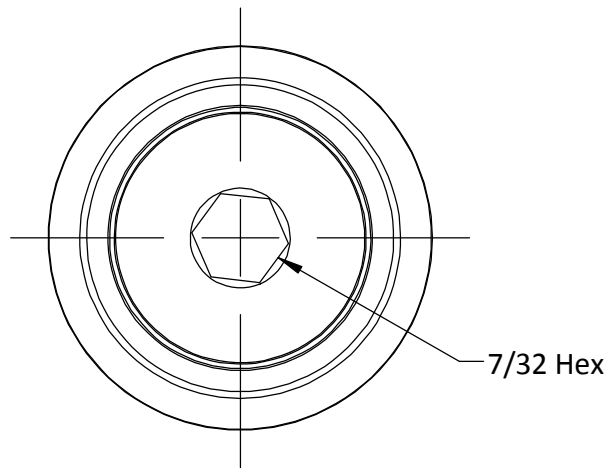

DO NOT SCALE DRAWING REV 2

This product may be covered by one or more patents or patent applications. See <http://www.standardlifters.com/patents.html> for details.

SE-1.00-.188-S-A-T

STANDARD LIFTERS INC

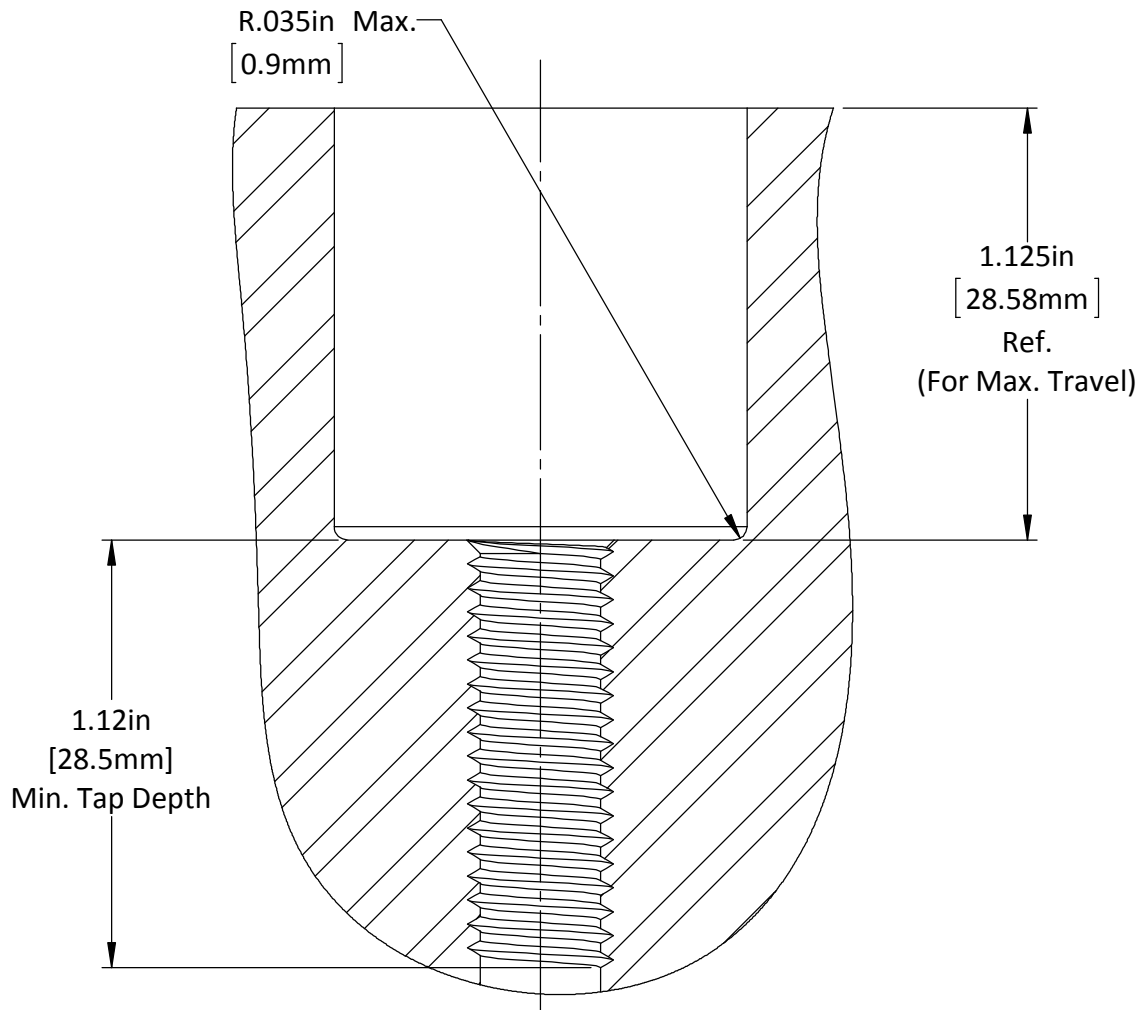
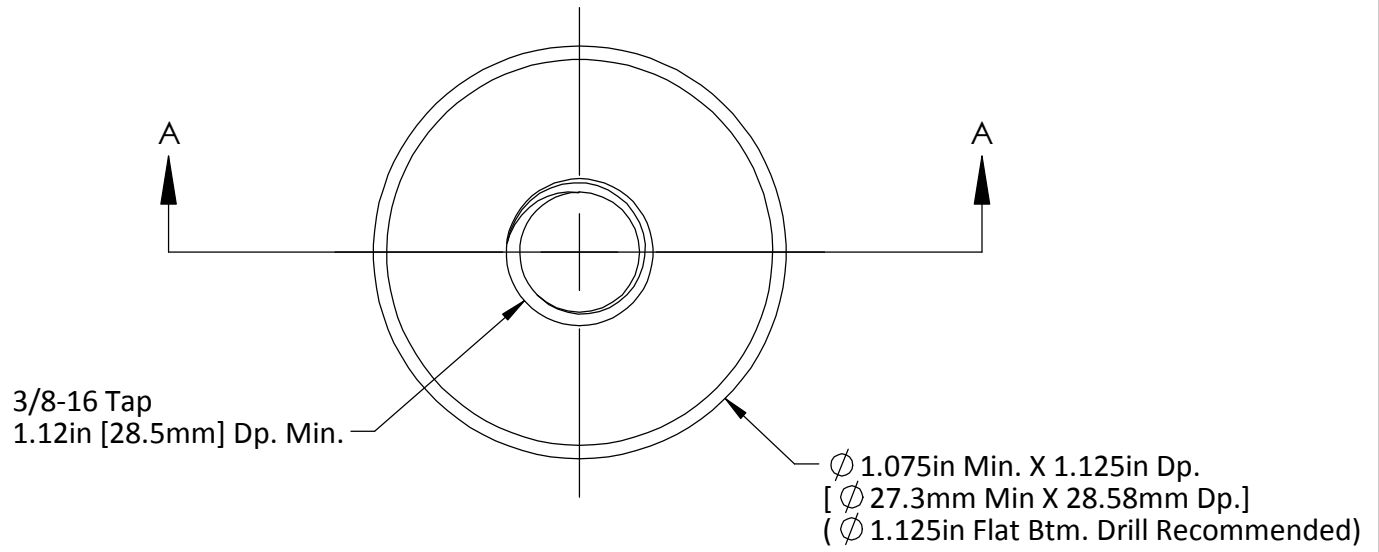

SECTION A-A

DO NOT SCALE DRAWING

REV 2

SE-1.00-.188-S-A-T-Machining

This product may be covered by one or more patents or patent applications.
See <http://www.standardlifters.com/patents.html> for details.

STANDARD LIFTERS INC

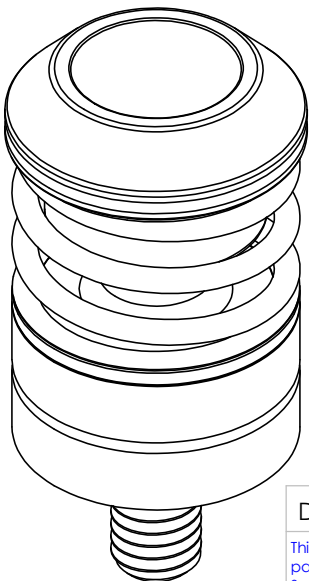
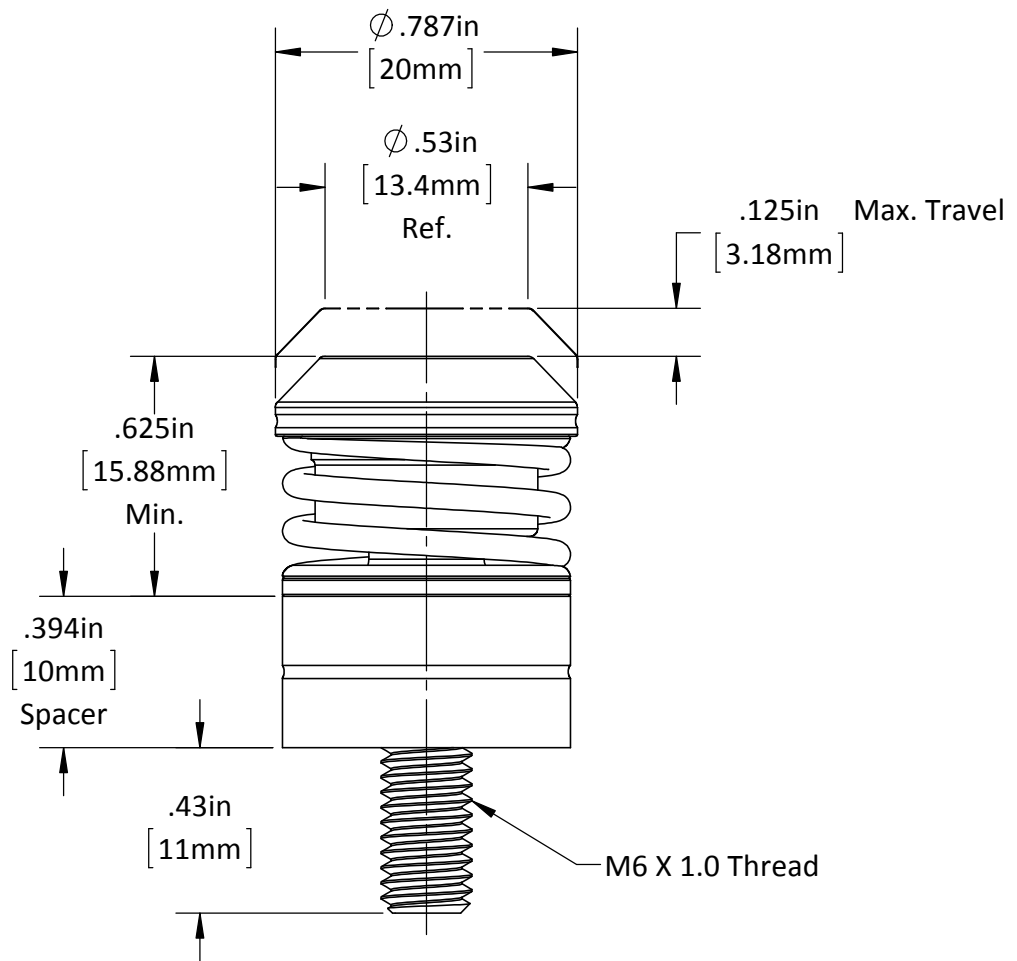
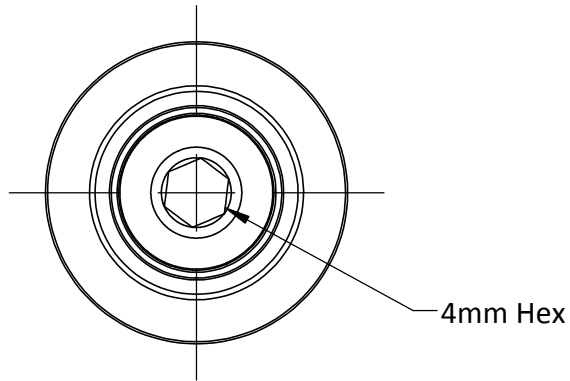

DO NOT SCALE DRAWING REV 1

This product may be covered by one or more patents or patent applications.
 See <http://www.standardlifters.com/patents.html> for details.

SE-20mm-3.2mm-S-A-T

STANDARD LIFTERS INC

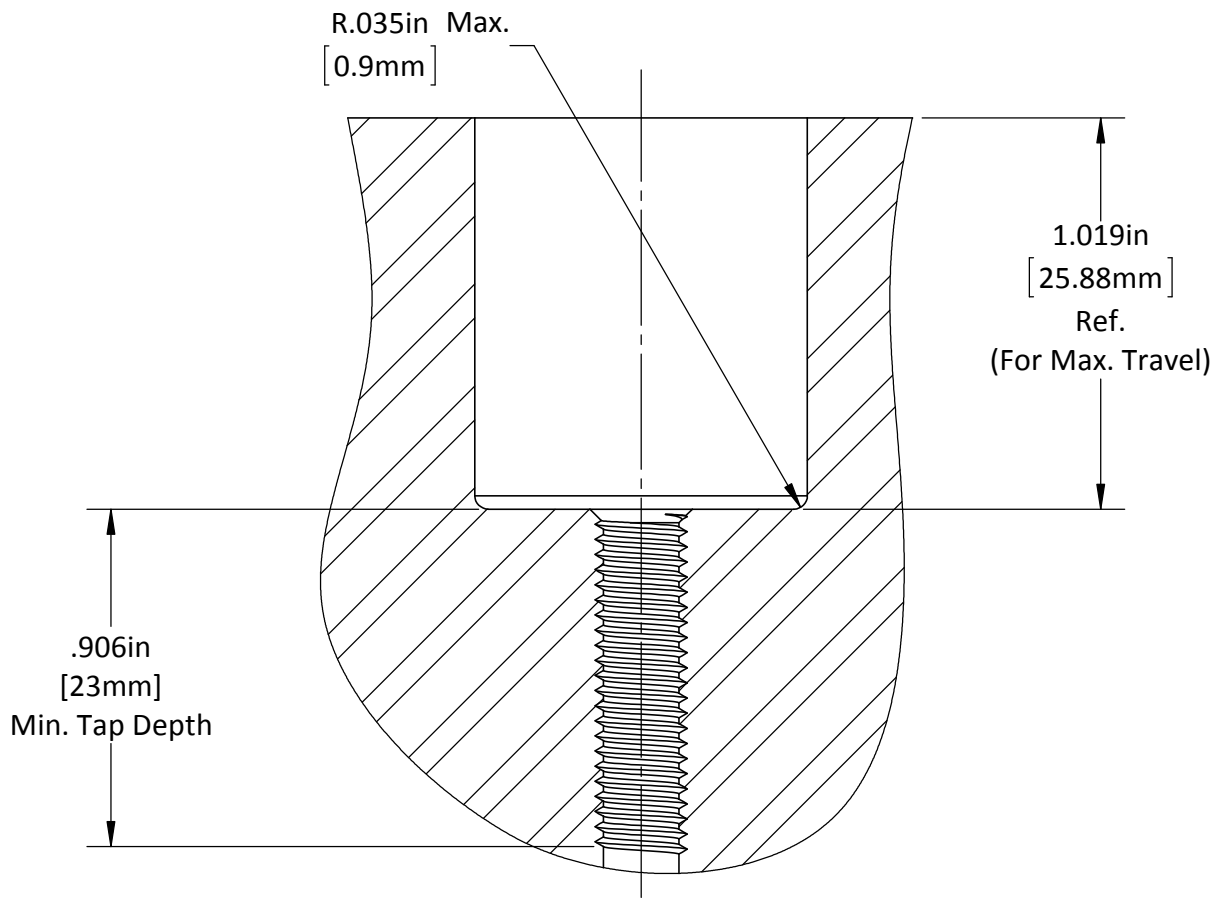
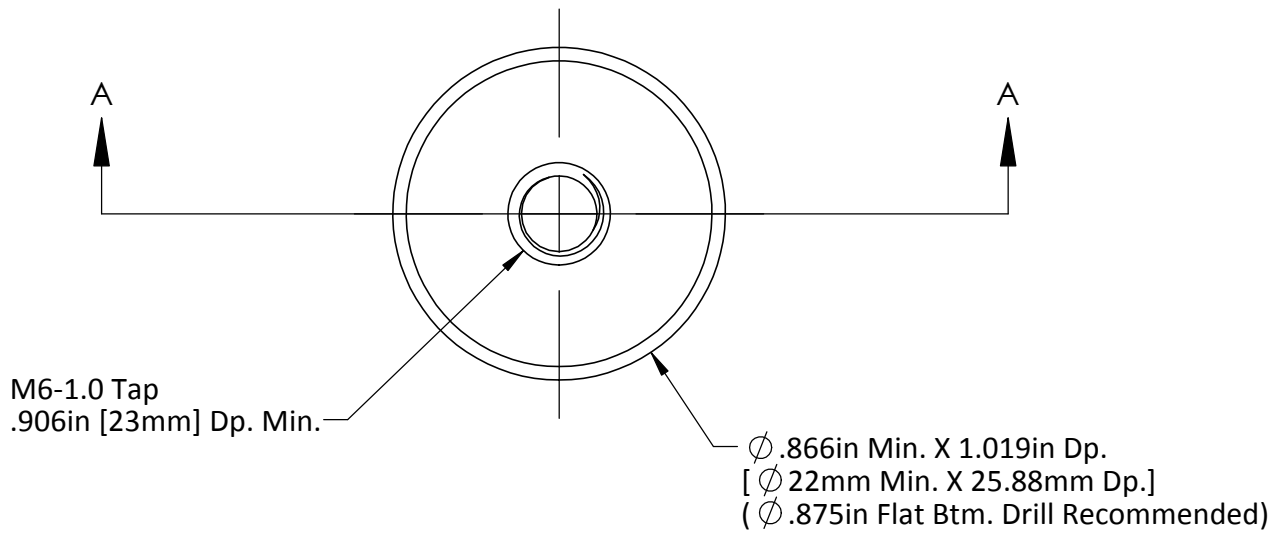

SECTION A-A

DO NOT SCALE DRAWING REV 1

This product may be covered by one or more patents or patent applications.
See <http://www.standardlifters.com/patents.html> for details.

SE-20mm-3.2mm-S-A-T-Machining

STANDARD LIFTERS INC

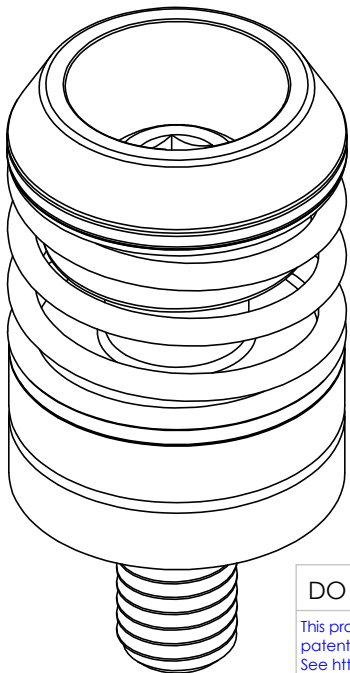
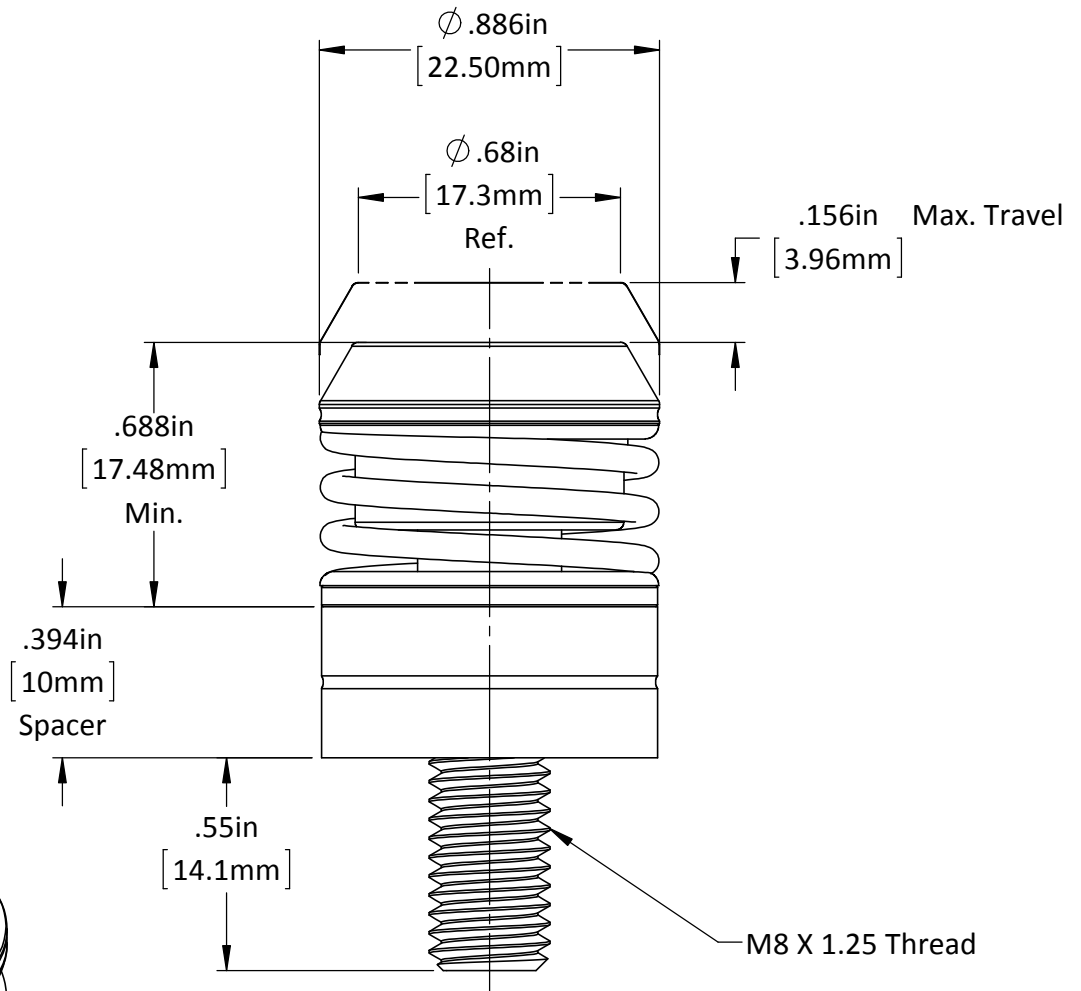
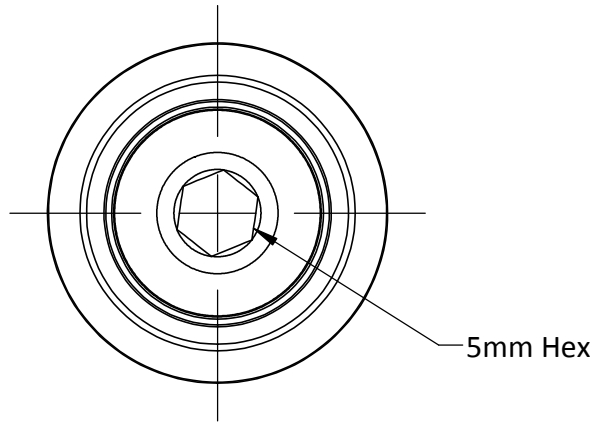

DO NOT SCALE DRAWING REV 1

This product may be covered by one or more patents or patent applications.
See <http://www.standardlifters.com/patents.html> for details.

SE-22.5mm-4mm-S-A-T

STANDARD LIFTERS INC

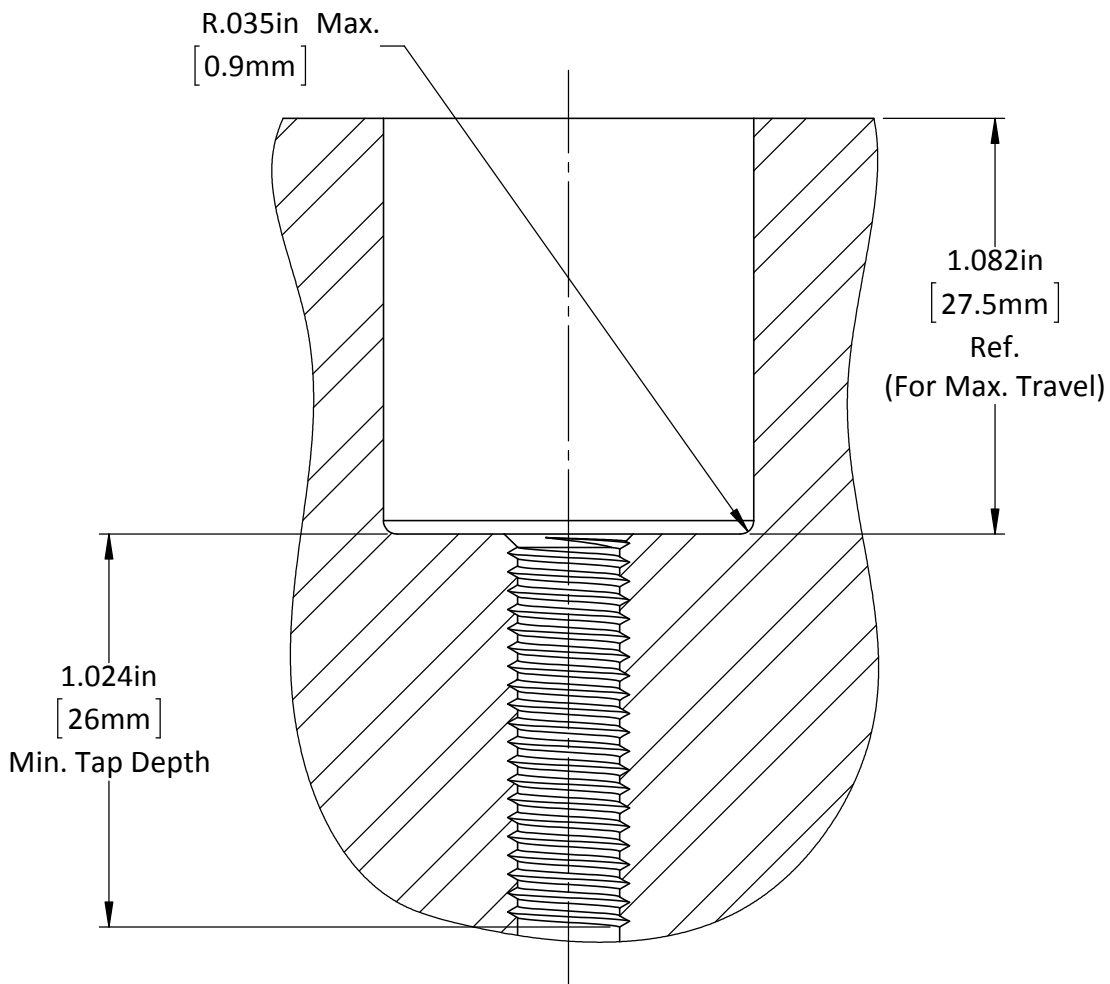
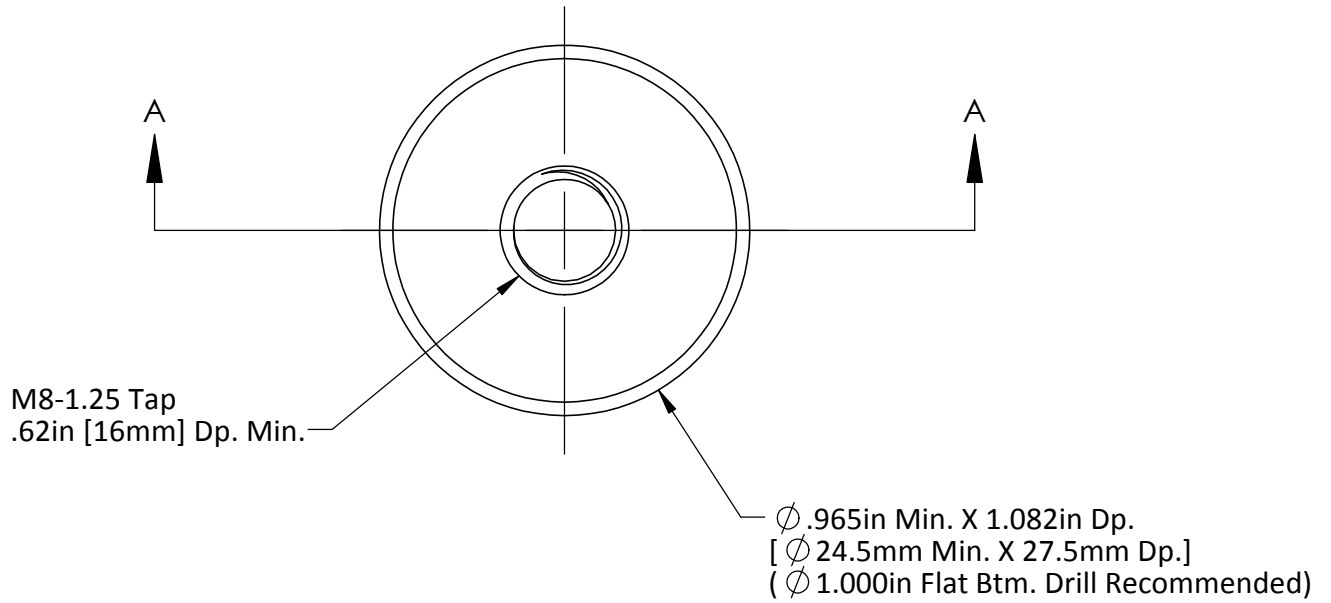

SECTION A-A

DO NOT SCALE DRAWING REV 1

This product may be covered by one or more patents or patent applications.
See <http://www.standardlifters.com/patents.html> for details.

SE-22.5mm-4mm-S-A-T-Machining

STANDARD LIFTERS INC

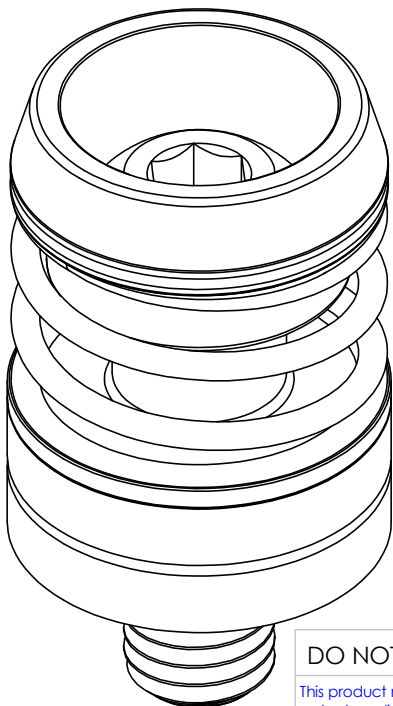
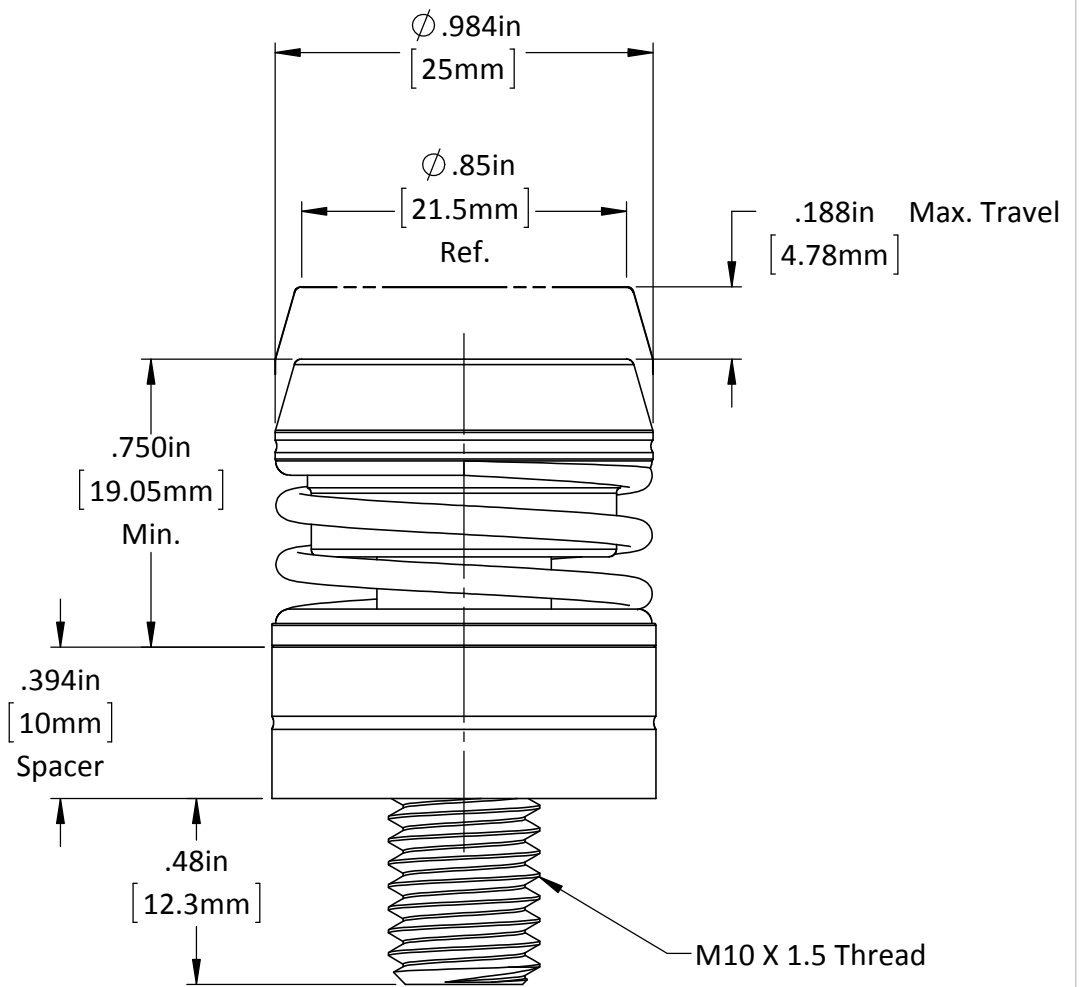
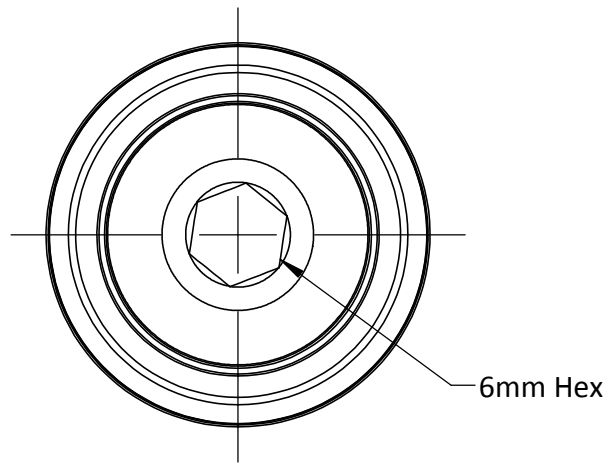

DO NOT SCALE DRAWING REV 1

This product may be covered by one or more patents or patent applications.
 See <http://www.standardlifters.com/patents.html> for details.

SE-25mm-4.8mm-S-A-T

STANDARD LIFTERS INC

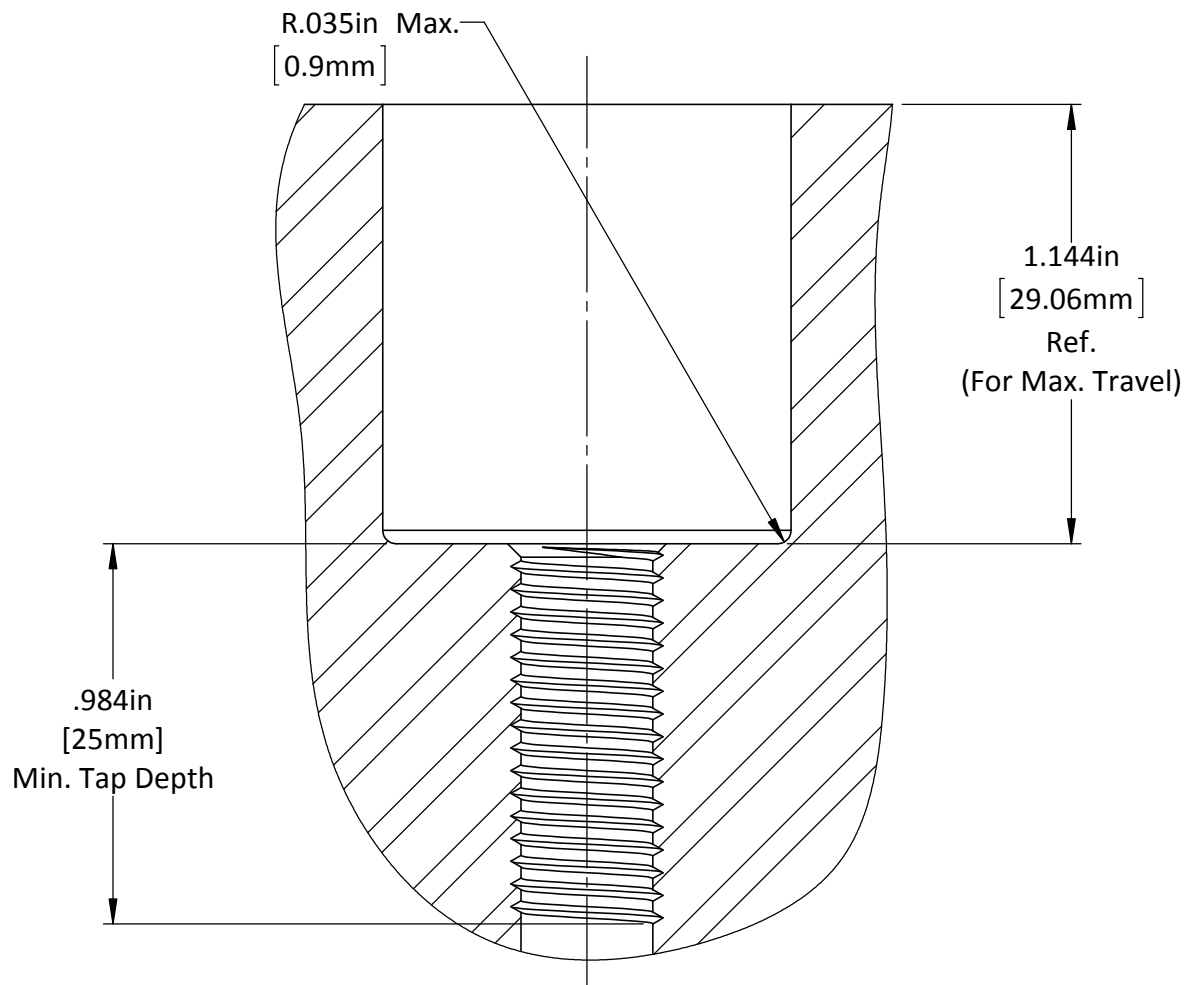
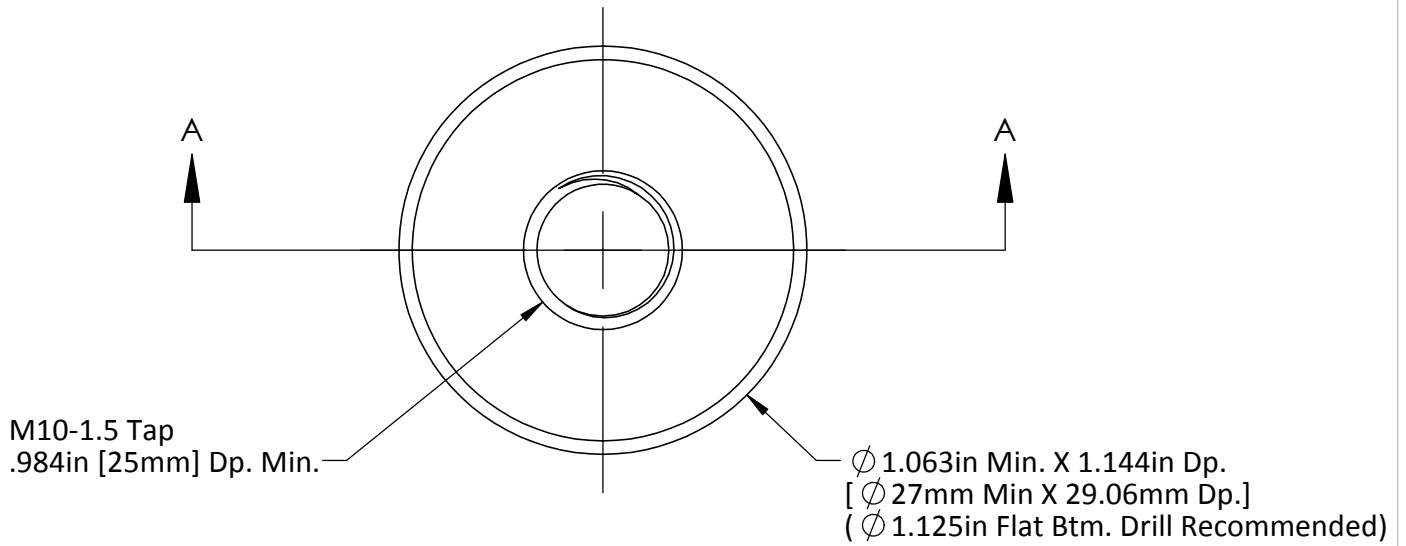

SECTION A-A

DO NOT SCALE DRAWING

REV 1

SE-25mm-4.8mm-S-A-T-Machining

This product may be covered by one or more patents or patent applications.
See <http://www.standardlifters.com/patents.html> for details.

STANDARD LIFTERS INC