

*** Caution: English & Metric Hole Locations are NOT the Same!**

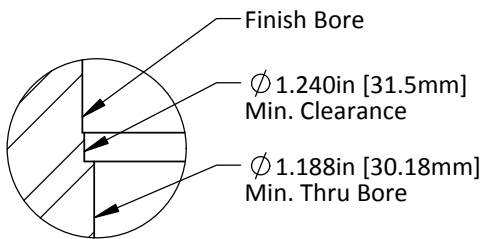

DETAIL SCALE :

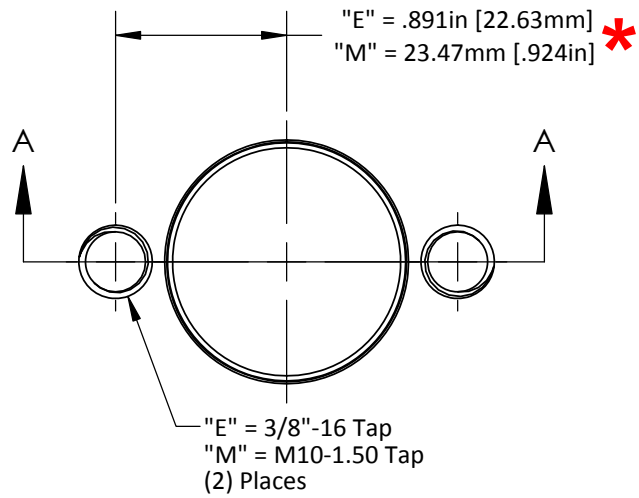
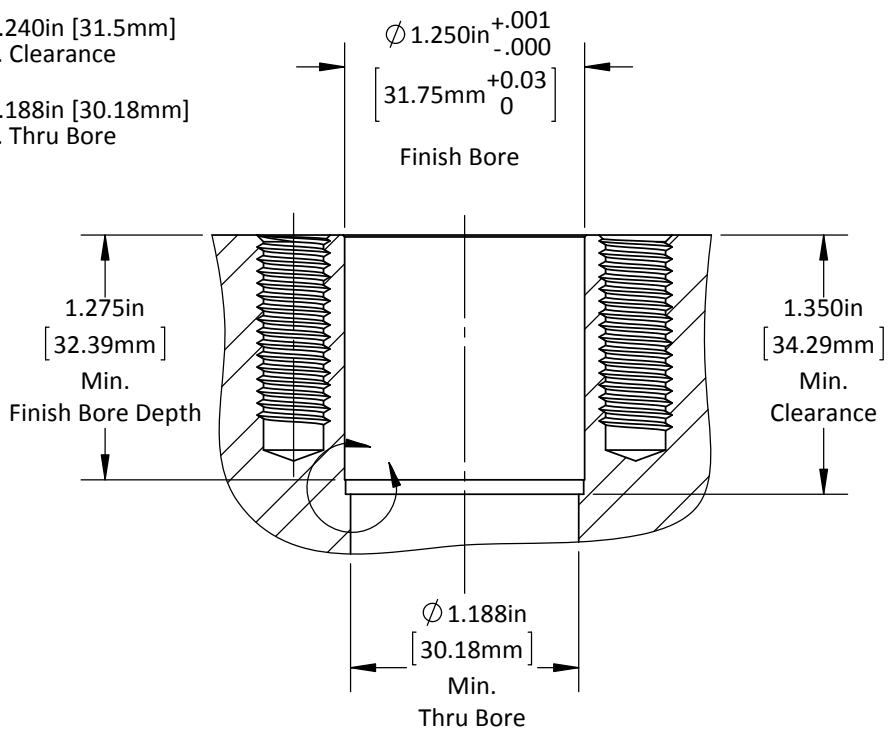

| | |
|--|-------|
| DO NOT SCALE DRAWING | REV 2 |
| This product may be covered by one or more patents or patent applications. See http://www.standardlifters.com/patents.html for details. | |

GK75-H2-Base Machining
STANDARD LIFTERS INC

*** Caution: English & Metric Hole Locations are NOT the Same!**

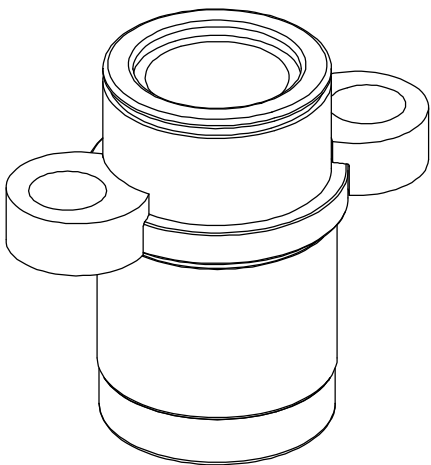
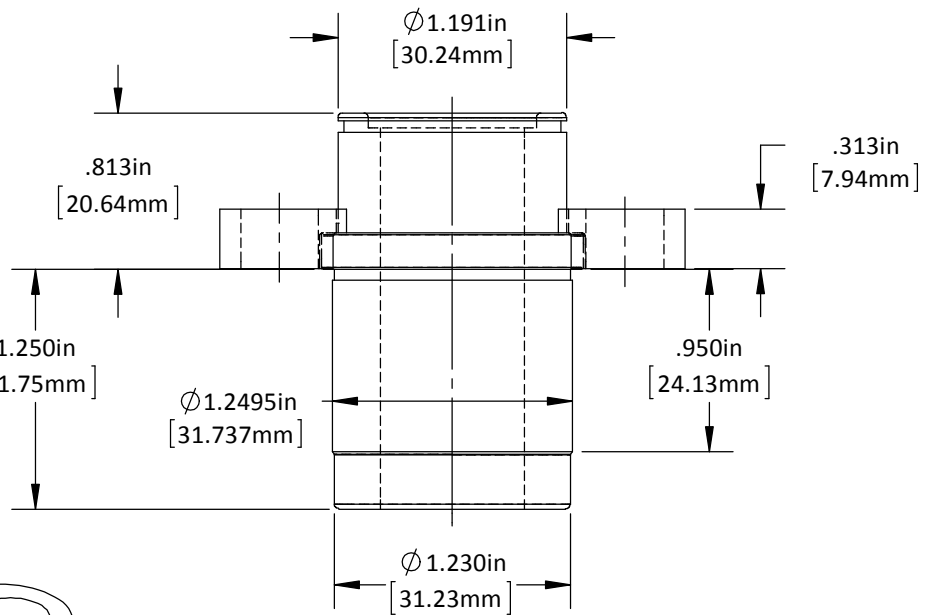
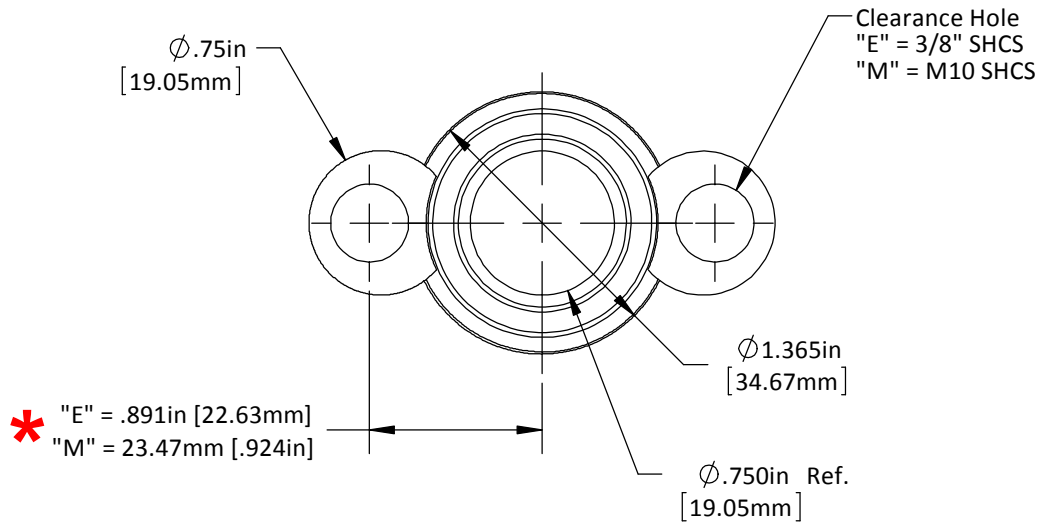

DO NOT SCALE DRAWING REV 2
 This product may be covered by one or more patents or patent applications.
 See <http://www.standardlifters.com/patents.html> for details.

Base-GK75-H2
STANDARD LIFTERS INC