

DO NOT SCALE DRAWING

REV 2

This product may be covered by one or more patents or  
 patent applications.  
 See <http://www.standardlifters.com/patents.html> for details.

**GK75-D2-Base Machining**

**STANDARD LIFTERS INC**

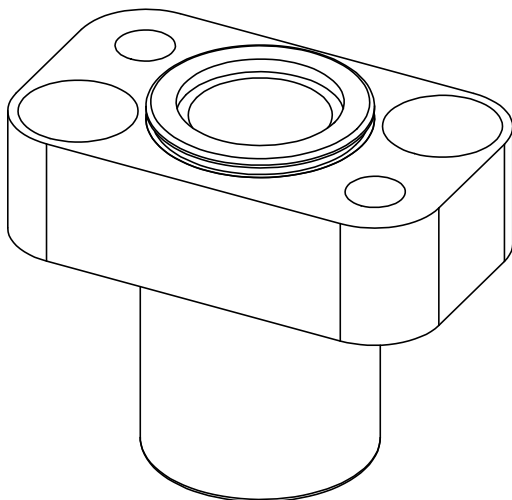
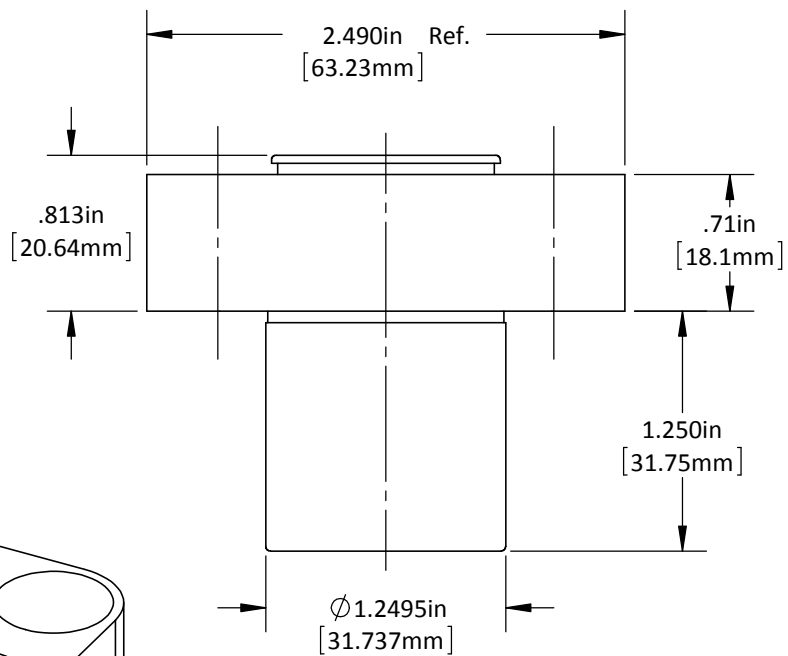
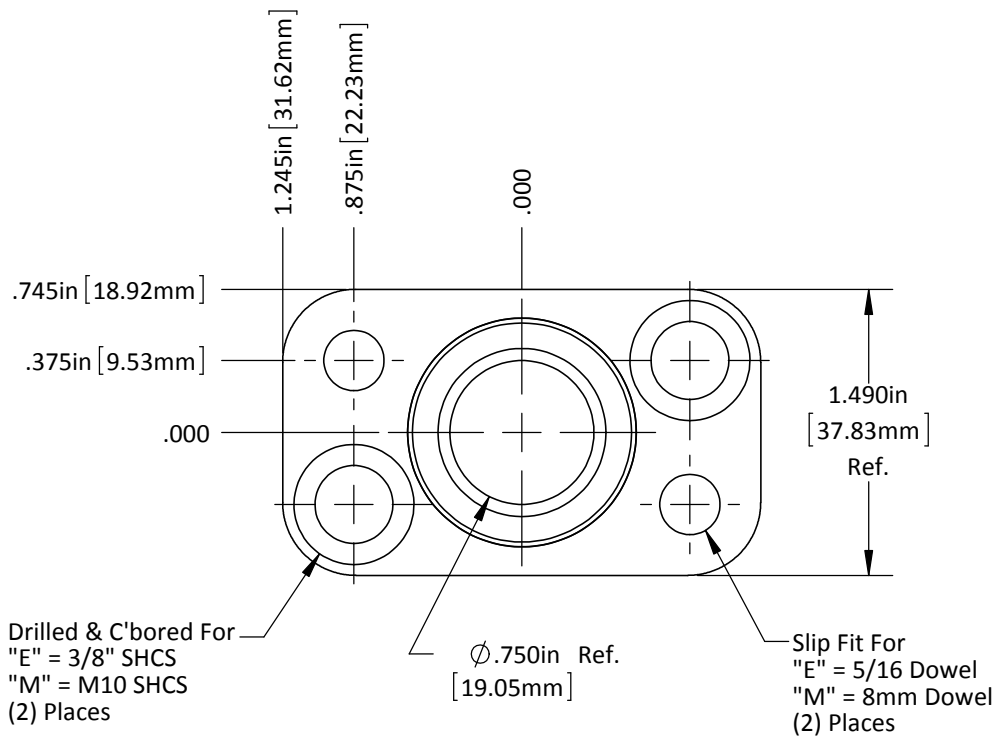

DO NOT SCALE DRAWING

REV 1

This product may be covered by one or more patents or patent applications.  
See <http://www.standardlifters.com/patents.html> for details.

**Base-GK75-D2**

**STANDARD LIFTERS INC**