

DO NOT SCALE DRAWING	REV 1
This product may be covered by one or more patents or patent applications. See http://www.standardlifters.com/patents.html for details.	

GK75-A-Base Machining
STANDARD LIFTERS INC

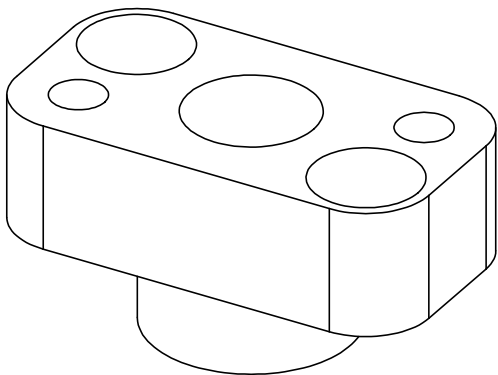
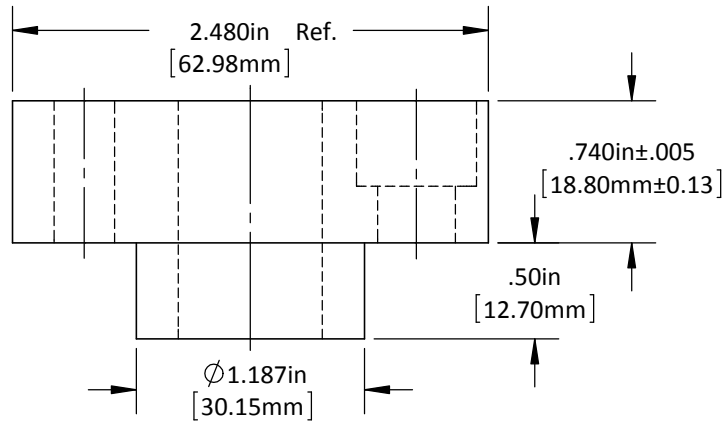
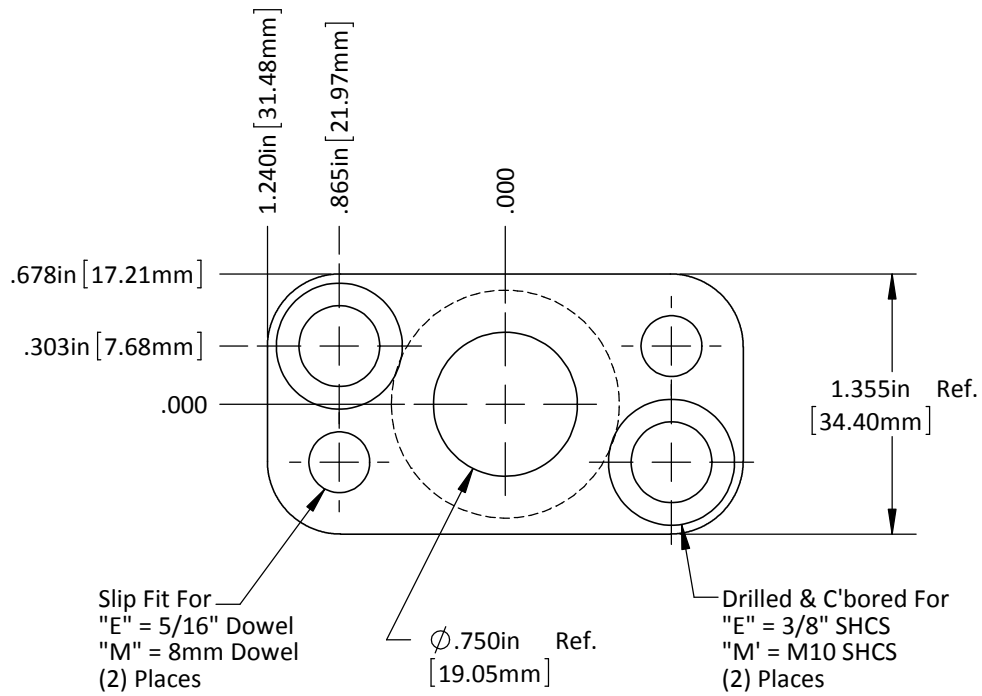

DO NOT SCALE DRAWING REV 1
This product may be covered by one or more patents or patent applications.
See <http://www.standardlifters.com/patents.html> for details.

Base-GK75-A
STANDARD LIFTERS INC